

esi

Electro Scientific Industries

13900 N.W. SCIENCE PARK DRIVE • PORTLAND, OREGON 97229

**BRIDGES
AND
ACCESSORIES**

FEBRUARY 1966

MODEL
242B

Instruction Manual
**PRECISION RESISTANCE
MEASURING
SYSTEM**

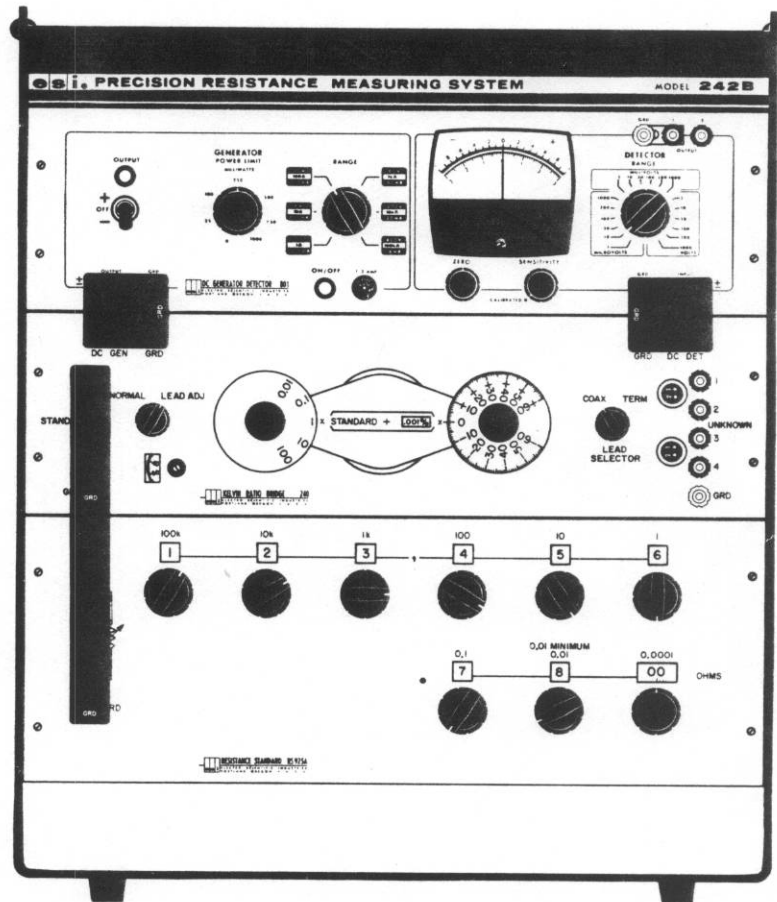

SERIAL NUMBER: _____

PART NUMBER: 8770

The following table lists the most recent revision of each page at the present date of printing:

<u>PAGES</u>	<u>DATE</u>
Title	2/66
A	2/66
i and ii	2/66
1-1 and 1-2	2/66
2-1 thru 2-5	2/66

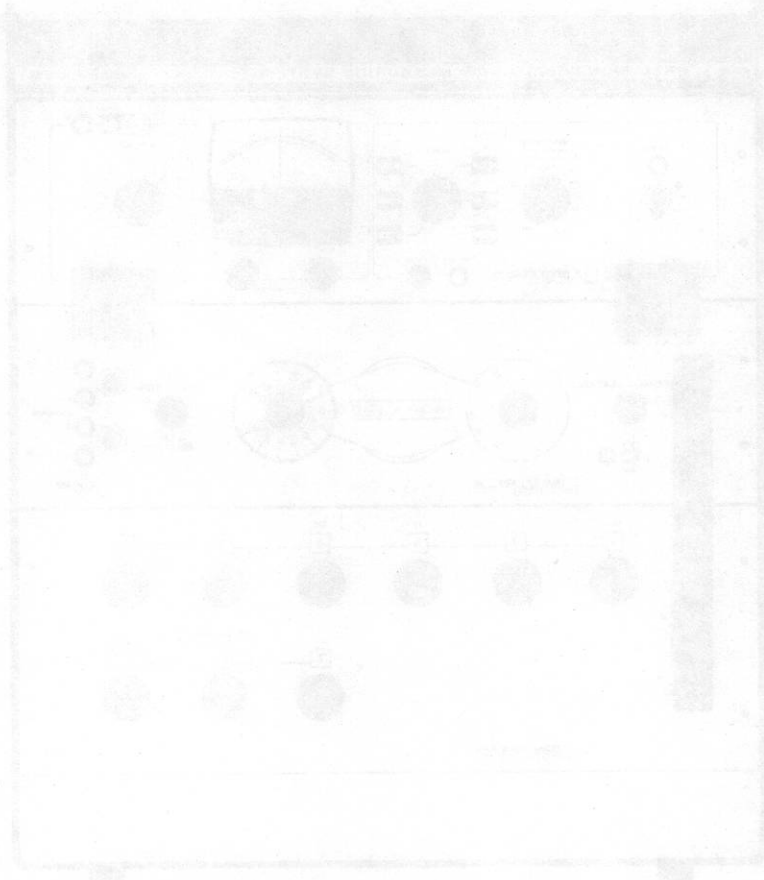

TABLE OF CONTENTS

MODEL 242B RESISTANCE MEASURING SYSTEM

1. Introduction
2. Operation
 - 2.1 Operating Instructions
 - 2.2 Lead Compensator

MODEL 240 KELVIN RATIO BRIDGE, INSTRUCTION MANUAL

MODEL RS 925A RESISTANCE STANDARD, INSTRUCTION MANUAL

MODEL 801 DC GENERATOR-DETECTOR, INSTRUCTION MANUAL

The following are registered trademarks of Electro Scientific Industries, Inc.:

ESI® Electro Scientific Industries, Inc.
ESIAC® Algebraic Computer
ESIPOT® Potentiometer
DEKABOX® Decade Resistors and Capacitors
DEKABRIDGE® Bridge Circuit
DEKADIAL® Decade Dials
DEKAMATIC® Automatic Unit
DEKAPOT® Decade Potentiometers
DEKASTAT® Decade Rheostat
DEKAPACITOR® Decade Capacitor
DEKAVIDER® Decade Voltage Divider
KELVIN KLIPS® Four-terminal Clips
KELVIN KLAMPS® Four-terminal Clamps
PORTAMETRIC® Portable Measuring Instrument
PVB® Potentiometric Voltmeter Bridge

Application for registration has been filed for the following:

DEKATRAN Decade Transformer

MODEL 242B RESISTANCE MEASURING SYSTEM

1. INTRODUCTION

The Model 242B Resistance Measuring System provides the facility for making precision resistance measurements and comparing resistance standards. When used in conjunction with a set of Model SR 1010 Resistance Transfer Standards, the system can be used for accurately comparing different valued resistance standards. For example, a 100 ohm certified standard can be used for checking a 10,000 ohm resistor to an accuracy of a few ppm. The Model 242B is a major part of the equipment necessary for calibrating voltage dividers to highest accuracy. The technique for this procedure is given in Volume 1, Number 1 of Design Ideas.

This resistance measuring system consists of the Model 240 Kelvin Ratio Bridge, the Model RS 925A Decade Resistance Standard, and the Model 801 DC Generator-Detector. The value of the unknown resistor is read as the product of a decade reading and a multiplier reading. A deviation dial is also provided for reading the difference between the actual ratio and the nominal ratio of the standard and unknown resistors in parts per million or percent.

The Model 240 Kelvin Ratio Bridge is a four-terminal comparison bridge using a modification of the Kelvin double-bridge circuit. The bridge is designed for four-terminal connections to eliminate test lead resistance in series with the unknown. It uses switches and terminals designed to minimize insulation leakage in parallel with the unknown.

The Model RS 925A Decade Resistance Standard provides resistance values from 10 milliohms to 1.2 megohms in 100 microhm steps. The usual zero resistance problem is eliminated by not going below 10 milliohms. The lead and contact resistance make up part of the 10 milliohm resistors so that the resistance that the bridge sees is the same that the dials read. A four-terminal connection is made to the bridge so that lead and contact resistance problems between the units are avoided.

The Model 801 DC Generator-Detector provides an optimum signal source and null detector combination for the Model 242B system. Six generator voltage-resistance combinations are available so that the generator can be matched to the bridge input over a wide range of measurement values. To protect the bridge and the components being measured, each voltage-resistance combination is chosen so that no more than one watt can be supplied to the bridge. The detector has a sensitivity that approaches the theoretical noise limit. It has maximum protection from hum pickup. Provision has been made for operation by an external switch.

Specifications for the Model 242B Resistance Measuring System are summarized in Figures 1-1, 1-2, and 1-3. The resolution, accuracy, and sensitivity are shown in proportional parts (as well as parts per million and percent) of the measured resistance.

tion and accuracy shown in Figures 1-1 and 1-2 are characteristics of the Model 5A Resistance Standard (solid lines) and the Model 240 Kelvin Ratio Bridge (dashed lines) regardless of generator or detector. Sensitivity shown in Figure 1-3 is as maximum power and detector sensitivity of the Model 801 Generator-Detector.

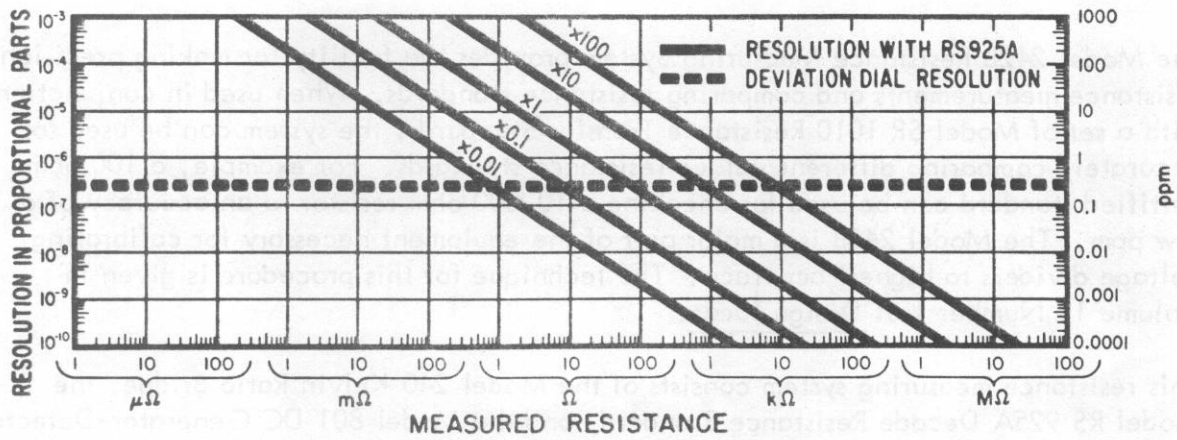

Figure 1-2, Model 242B Accuracy

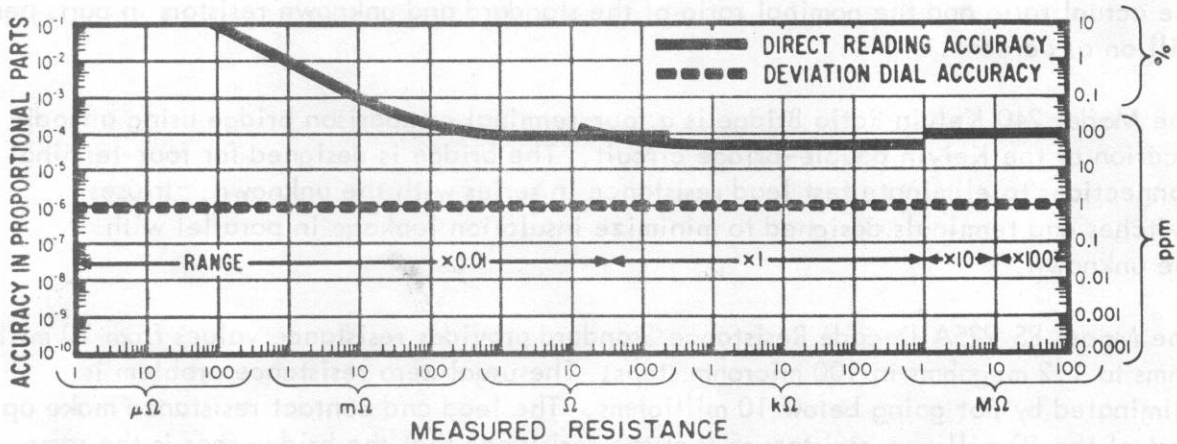

Figure 1-1, Model 242B Resolution

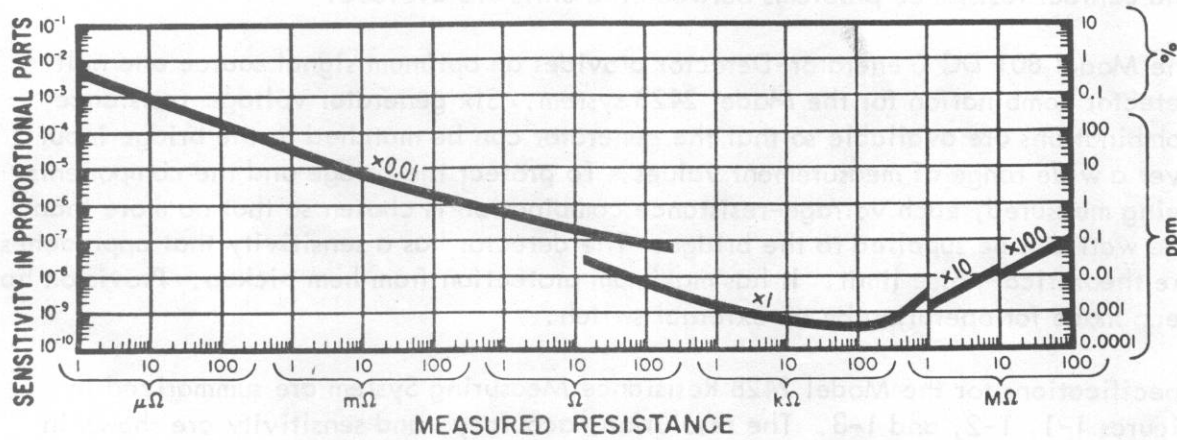

Figure 1-3, Model 242B Sensitivity

2. OPERATION

Interconnection of the units is shown in Figure 2-1.

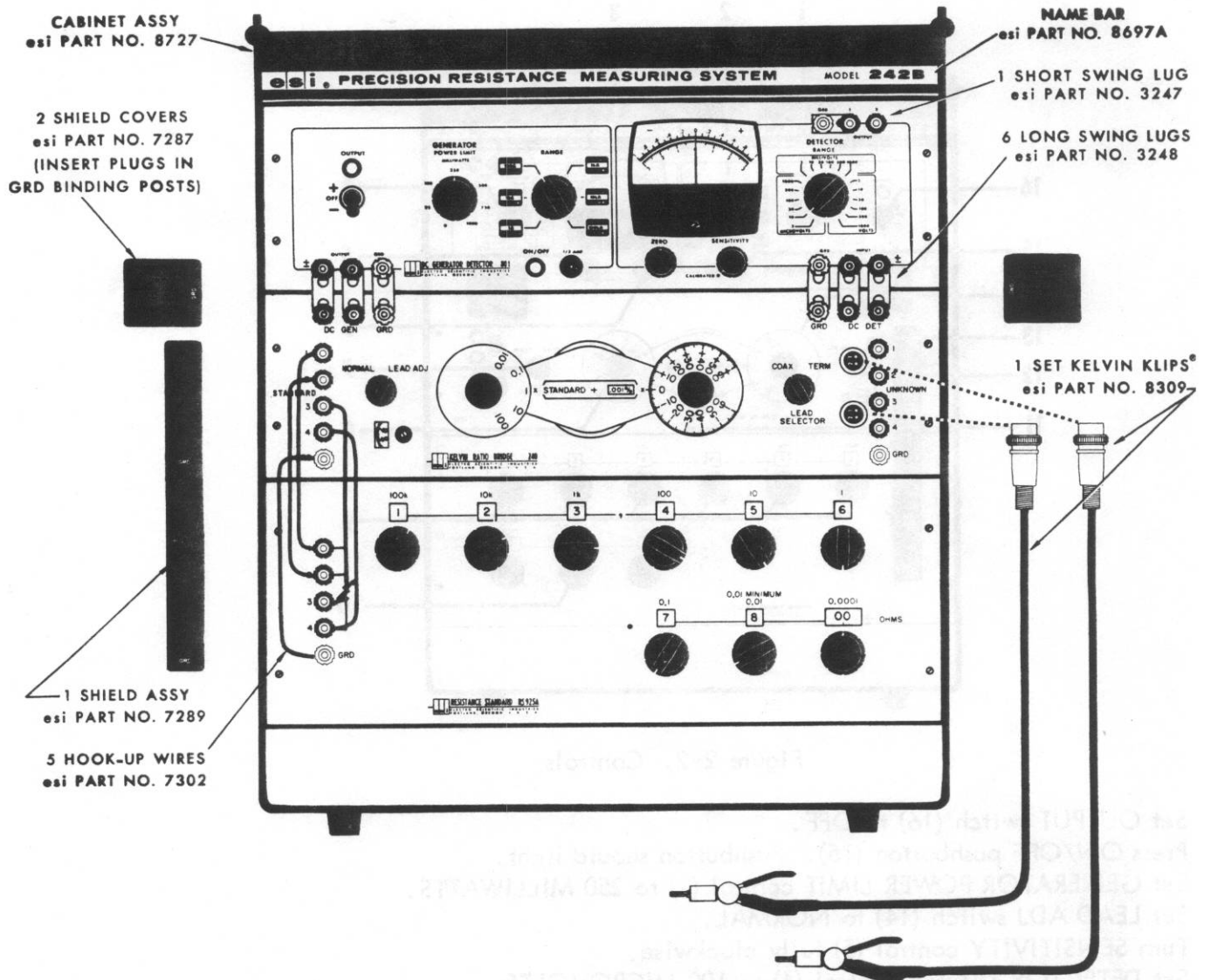

Figure 2-1, Interconnection of Model 242B

Basic operating instructions for the instrument are given in the following paragraph. More detailed instructions for operation, maintenance, etc. are included in the manuals for the individual instruments.

I Operating Instructions

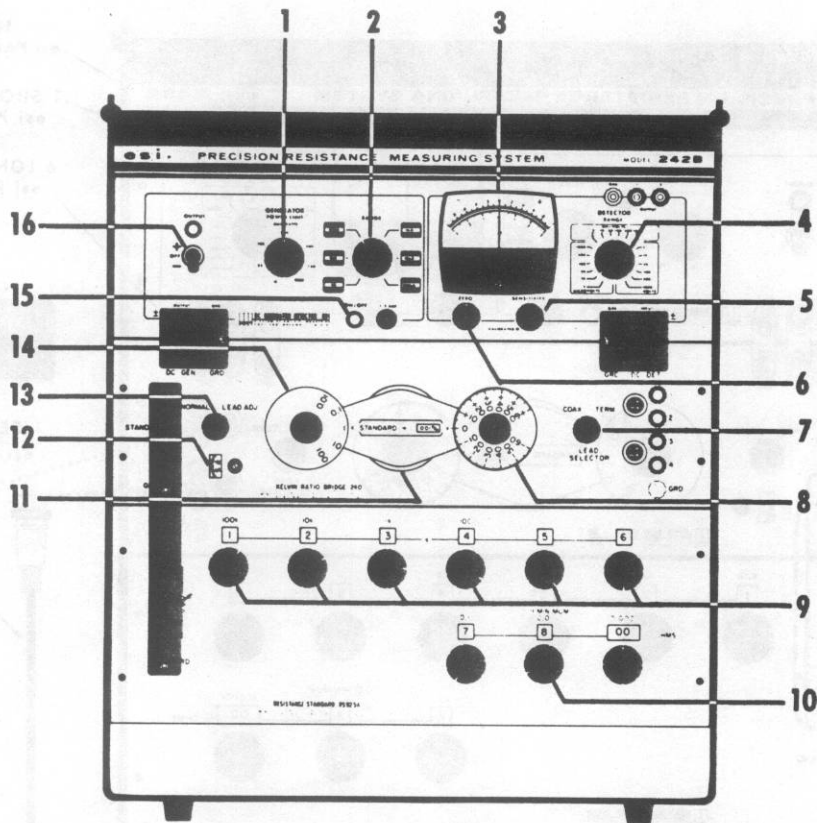

Figure 2-2, Controls

Set OUTPUT switch (16) to OFF.

Press ON/OFF pushbutton (15). Pushbutton should light.

Set GENERATOR POWER LIMIT control (1) to 250 MILLIWATTS.

Set LEAD ADJ switch (14) to NORMAL.

Turn SENSITIVITY control (5) fully clockwise.

Set DETECTOR RANGE control (4) to 100 MICROVOLTS.

Adjust ZERO control (6) for null indication on meter (3).

Set DETECTOR RANGE control (4) to 1000 MILLIVOLTS.

Connect resistor and set LEAD SELECTOR switch (8). Use appropriate position for the type of lead and test connection to be used. See Figure 2-3.

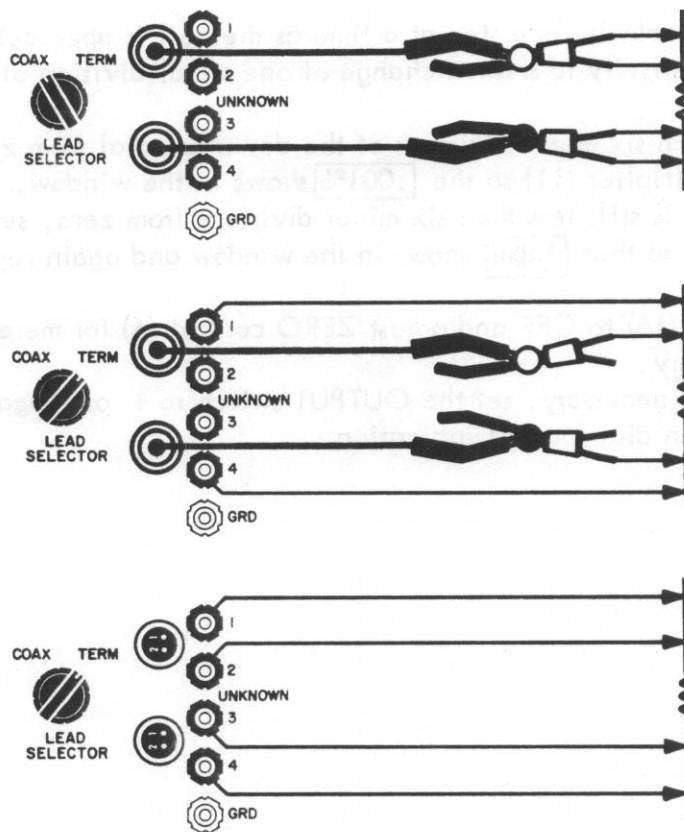

Figure 2-3, Test Connection

10. Set multiplier dial (12) according to table:

NOMINAL VALUE OF UNKNOWN RESISTOR	MULTIPLIER DIAL SETTING
12 M Ω to 120 M Ω	100
1.2 M Ω to 12 M Ω	10
10 Ω to 1.2 M Ω	1
0.1 Ω to 10 Ω	0.1
0.1 m Ω to 0.1 Ω	0.01

11. Set decade resistance dials (9) to nominal value of unknown resistance. Note that the 0.01 dial (10) will not go to zero. This means in most cases a sequence of zeros must be represented by a sequence of nines followed by TEN. For example, 1,000.00 ohms must be set as 9 9 9 . 9 TEN.
12. Set deviation multiplier (11) so that **.01%** shows in window.
13. Set OUTPUT switch (16) to - to turn on generator.
14. Turn DETECTOR RANGE control (4) counterclockwise slowly (wait about 3 seconds on each step) until meter (3) indicates approximately .2 on the upper scale.

control (4) counterclockwise one step at a time as the null is approached. Use only enough sensitivity to show a change of one minor division of the deviation dial.

If the null is less than six minor divisions of the deviation dial from zero, set the deviation multiplier (11) so the **.001%** shows in the window. Repeat Step 16. If the null is still less than six minor divisions from zero, set the deviation multiplier so that **1ppm** shows in the window and again repeat Step 16.

Set OUTPUT switch (16) to OFF and adjust ZERO control (6) for meter zero indication if necessary.

If an adjustment was necessary, set the OUTPUT switch to + or - again and readjust the deviation dial for null indication.



Figure 2-4. Test Connection

10. Set multiplier dial (12) according to table.

MULTIPLIER DIAL SETTING	NOMINAL VALUE OF UNKNOWN RESISTOR
100	12 MΩ to 120 MΩ
10	1.2 MΩ to 12 kΩ
1	10 Ω to 1.2 MΩ
0.1	0.1 Ω to 10 Ω
0.01	0.1 mΩ to 0.1 Ω

11. Set decade resistance dial (9) to nominal value of unknown resistance. Note that the 0.01 dial (10) will not go to 0. This means in most cases a value of zero must be represented by a sequence of nine followed by 01. For example, 1,000 Ω must be set as 9 9 9 9 9 9 9 9 9 01.

12. Set deviation multiplier (11) so that **.01%** shows in window.

13. Set OUTPUT switch (16) to - to turn on generator.

14. Turn DETECTOR RANGE control (4) counterclockwise slowly (wait about 2 seconds on each step) until meter (5) indicates approximately 2 on the upper scale.

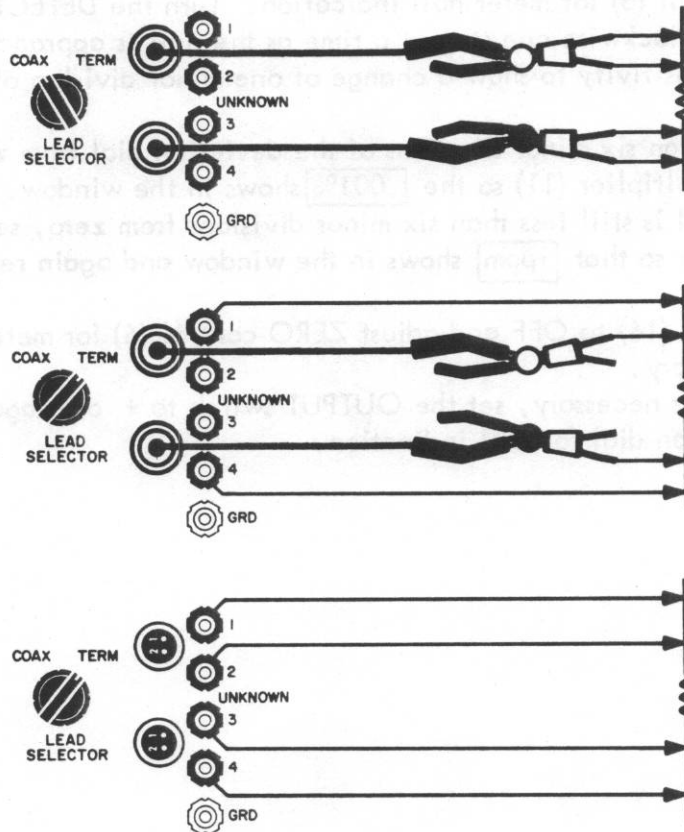

Figure 2-3, Test Connection

10. Set multiplier dial (12) according to table:

NOMINAL VALUE OF UNKNOWN RESISTOR	MULTIPLIER DIAL SETTING
12 M Ω to 120 M Ω	100
1.2 M Ω to 12 M Ω	10
10 Ω to 1.2 M Ω	1
0.1 Ω to 10 Ω	0.1
0.1 m Ω to 0.1 Ω	0.01

11. Set decade resistance dials (9) to nominal value of unknown resistance. Note that the 0.01 dial (10) will not go to zero. This means in most cases a sequence of zeros must be represented by a sequence of nines followed by TEN. For example, 1,000.00 ohms must be set as 9 9 9 . 9 TEN.
12. Set deviation multiplier (11) so that .01% shows in window.
13. Set OUTPUT switch (16) to - to turn on generator.
14. Turn DETECTOR RANGE control (4) counterclockwise slowly (wait about 3 seconds on each step) until meter (3) indicates approximately .2 on the upper scale.

Adjust GENERATOR RANGE control (2) for greatest meter deflection. Adjust deviation dial (8) for meter null indication. Turn the DETECTOR RANGE control (4) counterclockwise one step at a time as the null is approached. Use only enough sensitivity to show a change of one minor division of the deviation dial.

If the null is less than six minor divisions of the deviation dial from zero, set the deviation multiplier (11) so the **.001%** shows in the window. Repeat Step 16. If the null is still less than six minor divisions from zero, set the deviation multiplier so that **1ppm** shows in the window and again repeat Step 16.

Set OUTPUT switch (16) to OFF and adjust ZERO control (6) for meter zero indication if necessary.

If an adjustment was necessary, set the OUTPUT switch to + or - again and readjust the deviation dial for null indication.

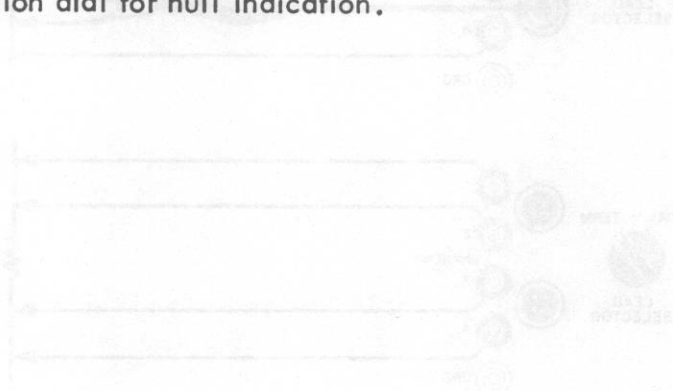

Figure 2-3. Test Connection

10. Set multiplier dial (12) according to table.

NOMINAL VALUE OF UNKNOWN RESISTOR	MULTIPLIER DIAL SETTING
12 MΩ to 150 MΩ	100
1.2 MΩ to 12 MΩ	10
10 Ω to 1.2 MΩ	1
0.1 Ω to 10 Ω	0.1
0.1 mΩ to 0.1 Ω	0.01

11. Set decade resistance dial (9) to nominal value of unknown resistor. Note that the 0.01 dial (10) will not go to zero. This means in most cases a separate zero must be represented by a sequence of nine's followed by 0's. For example, 1,000.00 ohms must be set as 9 9 9 9 9 00.00.
12. Set deviation multiplier (11) so that **0.001%** shows in window.
13. Set OUTPUT switch (16) to - to turn on generator.
14. Turn DETECTOR RANGE control (4) counterclockwise slowly; wait about 3 seconds on each step until meter (3) indicates approximately 2 on the upper scale.

2.2 Lead Compensation

Whenever a new set of leads are installed, they have to be compensated. The procedure is as follows:

1. Set LEAD ADJ switch (14) to LEAD ADJ.
2. Connect measurement leads as shown in the following diagrams, and set LEAD SELECTOR switch (7) to appropriate position.

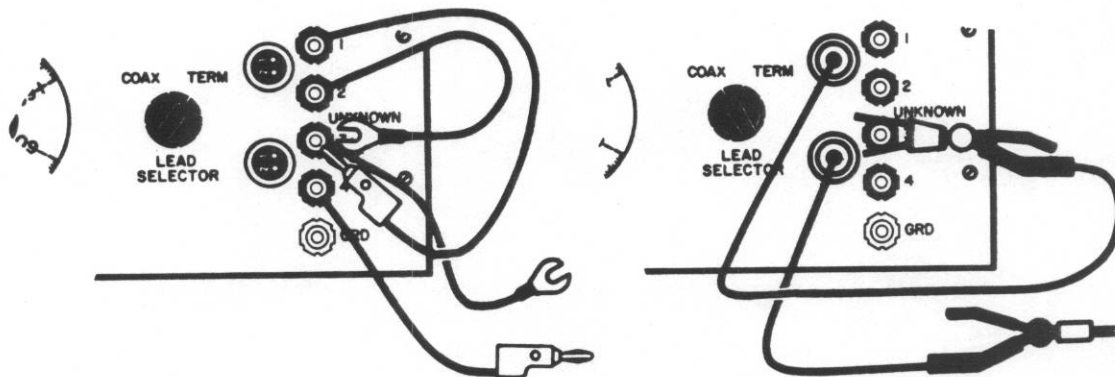

Figure 2-4, Lead Compensation

3. Turn GENERATOR POWER LIMIT control (1) fully clockwise and set GENERATOR RANGE to 10k Ω .
4. Set DETECTOR RANGE control (4) to 100 MICROVOLTS.
5. Adjust ZERO control (6) for meter (3) zero indication.
6. Set OUTPUT switch (16) to -
7. Adjust lead compensation trimmer (12) with a screwdriver until meter indicates null.
8. Set OUTPUT switch to OFF and note any change in meter zero. Readjust ZERO control if necessary.
9. If ZERO adjustment was necessary, repeat Steps 6, 7, and 8.
10. Set OUTPUT switch to OFF, LEAD ADJ switch to NORMAL, and connect test leads to the UNKNOWN terminals in the manner in which they will be used to make measurements.

AUGUST 1968

ESI[®] INSTRUCTION MANUAL CHANGES
Model 242B Precision Resistance Measuring System
Instruction Manual Dated February 1966

Page 2-2, paragraph 2.1: Change identifying numbers of controls in lines 4 and 9 as follows:

Line 4: Change (14) to (13)

Line 9: Change (8) to (7).

Part No. 8770-2

5519 INSTRUCTION MANUAL CHANGES

Model 2428 Precision Positioning System

Instruction Manual, Dated February 1988

Page 2-2, paragraph 2.1 - Change identification number of control in line 4 and 5 as follows:

Line 4: Change (14) to (13)

Line 5: Change (6) to (7)

Instruction Manual

FEBRUARY 1970
REPLACES AUGUST 1964

MODEL 240 KELVIN RATIO BRIDGE

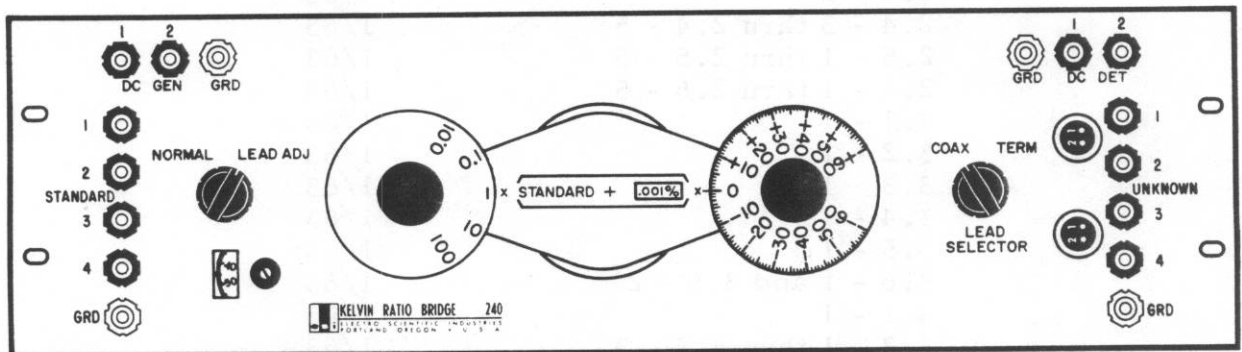

SERIAL NUMBER: _____

PART NUMBER: 8303

esi[®]

Electro Scientific Industries

13900 N. W. SCIENCE PARK DRIVE, PORTLAND, OREGON 97229

The following table lists the most recent revision of each page at the present printing:

<u>PAGES</u>	<u>DATE</u>
Title	2/70
A	2/70
i	8/64
ii	2/70
1.1 - 1	1/63
1.2 - 1	8/64
1.3 - 1 thru 1.3 - 3	1/63
2.1 - 1 and 2.1 - 2	1/63
2.2 - 1 thru 2.2 - 3	1/63
2.3 - 1 thru 2.3 - 3	1/63
2.4 - 1	1/63
2.4 - 2	9/63
2.4 - 3 thru 2.4 - 5	1/63
2.5 - 1 thru 2.5 - 5	1/63
2.6 - 1 thru 2.6 - 5	1/63
3.1 - 1	1/63
3.2 - 1	1/63
3.3 - 1	1/63
3.4 - 1	1/63
3.5 - 1	1/63
3.6 - 1 and 3.6 - 2	1/63
4.1 - 1	1/63
4.2 - 1 thru 4.2 - 3	1/63
4.2 - 4 and 4.2 - 5	8/64
4.3 - 1 thru 4.3 - 3	1/63
4.3 - 4	8/64
4.3 - 5 and 4.3 - 6	1/63
4.4 - 1 thru 4.4 - 4	1/63
4.5 - 1 and 4.5 - 2	1/63
5.1 - 1 thru 5.1 - 3	1/63
5.2 - 1	1/63
5.3 - 1 and 5.3 - 2	8/64
5.4 - 1	8/64
5.4 - 2 thru 5.4 - 4	1/63
5.4 - 5	8/64

TABLE OF CONTENTS

- I DESCRIPTION AND SPECIFICATIONS
 - 1.1 DESCRIPTION
 - 1.2 SPECIFICATIONS
 - 1.3 ACCESSORY REQUIREMENTS

- II OPERATING INSTRUCTIONS
 - 2.1 CONTROLS, INDICATORS, AND TERMINALS
 - 2.2 BASIC OPERATING PROCEDURE
 - 2.3 PRECISION RESISTANCE CALIBRATION PROCEDURES
 - 2.4 GENERATOR-DETECTOR CONNECTIONS
 - 2.5 UNKNOWN AND STANDARD RESISTOR CONNECTIONS
 - 2.6 LEAD RESISTANCE COMPENSATION ADJUSTMENT

- III THEORY OF OPERATION
 - 3.1 GENERAL
 - 3.2 STANDARD MULTIPLIER RATIOS
 - 3.3 LEAD RESISTANCE COMPENSATION ADJUSTMENT
 - 3.4 DEVIATION DIALS
 - 3.5 GUARDING
 - 3.6 ACCURACY ANALYSIS

- IV CALIBRATION
 - 4.1 INTRODUCTION
 - 4.2 INCREMENTAL ACCURACY
 - 4.3 MAIN RATIO CALIBRATION
 - 4.4 AUXILIARY RATIO CALIBRATION
 - 4.5 YOKE RESISTANCE

- V MAINTENANCE
 - 5.1 PREVENTIVE MAINTENANCE
 - 5.2 TROUBLE SHOOTING
 - 5.3 DIAGRAMS AND PHOTOGRAPHS
 - 5.4 PARTS LIST

The following are registered trademarks of Electro Scientific Industries, Inc.:

- ESI[®] Electro Scientific Industries, Inc.
- ESIAC[®] Algebraic Computer
- ESIPOT[®] Potentiometer
- DEKABOX[®] Decade Resistors and Capacitors
- DEKABRIDGE[®] Bridge Circuit
- DEKADIAL[®] Decade Dials
- DEKAMATIC[®] Automatic Unit
- DEKAPOT[®] Decade Potentiometers
- DEKASTAT[®] Decade Rheostat
- DEKAPACITOR[®] Decade Capacitor
- DEKAVIDER[®] Decade Voltage Divider
- KELVIN KLAMPS[®] Four-Terminal Clamps
- KELVIN KLIPS[®] Four-Terminal Clips
- PORTAMETRIC[®] Portable Measuring Instrument
- PVB[®] Potentiometric Voltmeter Bridge

SECTION I

DESCRIPTION AND SPECIFICATIONS

1.1 DESCRIPTION

The MODEL 240 KELVIN RATIO BRIDGE is designed to compare an unknown resistor with a standard resistor very accurately. The standard multiplier dial selects one of five multiplier ratios from 0.01 to 100. This permits comparison of resistors in the ratio of 10:1 or 100:1 as well as 1:1. The bridge deviation dial reads the difference between the actual ratio and the nominal ratio of the two resistors in percent or in parts per million.

Four-terminal connections are provided for both the standard and the unknown. The lead selector switch permits the option of connecting the bridge to the unknown resistor by means of binding posts or by shielded connectors, both of which are provided on the front panel of the bridge.

MULTIPLIER RATIO	RANGE	
	MIN	MAX
0.01	-50 ppm	50 ppm
0.1	-50 ppm	50 ppm
1	-50 ppm	50 ppm
10	-50 ppm	50 ppm
100	-50 ppm	50 ppm

1.2 SPECIFICATIONS

Multiplier Ratios:	0.01, 0.1, 1, 10, 100
Initial Adjustment Ratio Accuracy:	±10 ppm on 1:1 ratio, ±30 ppm on other ratios
Long-Term Ratio Accuracy:	Ratio will remain within ±50 ppm of nominal ratio for more than one year. The 1:1 range is adjustable to maintain initial accuracy.
Calibration Conditions:	23°C, with proper lead resistance adjustment
Temperature Coefficient of Ratio:	±2 ppm/°C on 1:1 ratio, ±5 ppm/°C on other ratios
Power Coefficient of Ratio:	±0.1 ppm/mw in ratio resistors
Power Rating:	1 watt total in ratio resistors
Lead Resistance:	A panel control compensates for resistance up to 100 milliohms in the test leads to the unknown.
Guarding:	The bridge is designed to prevent leakages from appearing across high resistance standard or unknown resistors.

Deviation Ranges:

RANGE		EACH DIAL DIVISION	
MIN	MAX	PPM	%
-60 ppm	60 ppm	1	0.0001
- 0.06%	0.06%	10	0.001
- 0.6%	0.6%	100	0.01

Deviation Accuracy:	±1 dial division.
Deviation Resolution:	1/4 dial division
Dimensions:	5-1/4 inches high, 19 inches wide, 7 inches deep
Weight:	11 lbs net

1.3 ACCESSORY REQUIREMENTS

To utilize the full capabilities of the MODEL 240 KELVIN RATIO BRIDGE it is necessary to choose an adequate dc generator and detector. Standard resistors must be available which are suitable for the measurement to be made. ESI combination generator-detector models are available with all the requirements listed below as built-in features. The ESI MODEL RS 925 DECADE RESISTANCE STANDARD was designed specifically as a wide-range working standard for the Model 240 bridge, and other ESI reference and transfer standards are available.

1.3.1 GENERATOR REQUIREMENTS

- a) The dc generator (which may be a battery) must be well insulated from ground, and preferably guarded, with a minimum leakage resistance of 10^{10} ohms from one terminal and 10^{12} ohms from the other terminal to ground.
- b) Generator switching must be guarded so that there are no measurable* leakage currents to ground in either the on or the off position. (*Measurable at the maximum sensitivity of the detector used.)
- c) The generator should be power-limited to a maximum of one watt, by a series resistance of at least $\frac{(E_{\max})^2}{4}$ for a generator open-circuit voltage of E_{\max} .
- d) Several different generator voltages, each with an appropriate limiting resistance, should be available for selection to yield maximum sensitivity in measuring different resistance values. If batteries are to be used the following typical combinations are suggested. The series limiting resistor must be capable of dissipating four watts.

Maximum Voltage (open circuit) (approx.)	Series Limiting Resistor (approx.)	Maximum Current (short circuit) (approx.)
1.5 volts	0.56 ohm	2.7 amps
6 volts	10 ohm	0.6 amp
22.5 volts	120 ohm	190 ma
90 volts	2.2 kilohms	41 ma
300 volts	22 kilohms	14 ma

- e) If a line-operated dc generator is used with a modulator type dc detector, the generator ac ripple output and the ac voltage from the output terminals to ground should be low enough to avoid ac interference problems in the dc detector. (The amount which can be tolerated depends upon the detector used.)

1.3.2 DETECTOR REQUIREMENTS

- a) For utilizing the full accuracy of the bridge, the detector should be capable of detecting dc signals very close to theoretical noise level at a source resistance in the vicinity of 10 kilohms. It must operate well with source resistances from 100 ohms to 1 megohm.
- b) The detector should be relatively insensitive to interference from ac signals into its input; the amount which can be tolerated will dictate the care which must be taken in shielding the measurement setup and selecting the generator to be used.
- c) A detector with internally grounded input may be used for all normal bridge applications, however, a detector with floating input will allow certain alternate modes of operation:
 - 1) If the detector can be operated with its low input terminal insulated from ground, but essentially at ground potential, a connection for lower sensitivity to ac pickup in low resistance measurements is possible.
 - 2) If the detector can be operated with its low input terminal at a high dc voltage above ground without observable indication (thorough guarding required), a connection for higher accuracy and sensitivity in high resistance measurements is possible.
- d) A shorting switch should be provided to momentarily short the detector input when turning the generator on and off, for measurements in which reactive transients are found to occur.

1.3.3 STANDARD RESISTOR REQUIREMENTS

- a) A four-terminal, shielded (guarded) construction is recommended for all resistance standards to be used with the bridge; the standard preferably should be four-terminal below 10 kilohms and guarded (three-terminal, shielded) above 10 kilohms.
- b) For highest accuracy calibration measurements, a working standard resistor should be available which has the same value as the resistor to be measured, within ± 60 ppm. It may be either certified or calibrated by transfer techniques.
- c) For measurements at one resistance value traceable to the calibration of a standard resistor of a different resistance value, series-parallel resistor build-up techniques should be used. ESI MODEL SR-1010 RESISTANCE TRANSFER STANDARDS are specifically designed for this transfer of calibration from one resistance level to another, with an accuracy of a few parts per million anywhere in the range from approximately one ohm to one megohm.
- d) For greatest versatility of measurement with the Model 240 bridge, a wide-range decade resistance standard can be left connected to the bridge as a working standard and the bridge standard multiplier used as a range selector. The ESI MODEL RS-925 DECADE RESISTANCE STANDARD is specifically designed for this use with the Model 240 bridge.

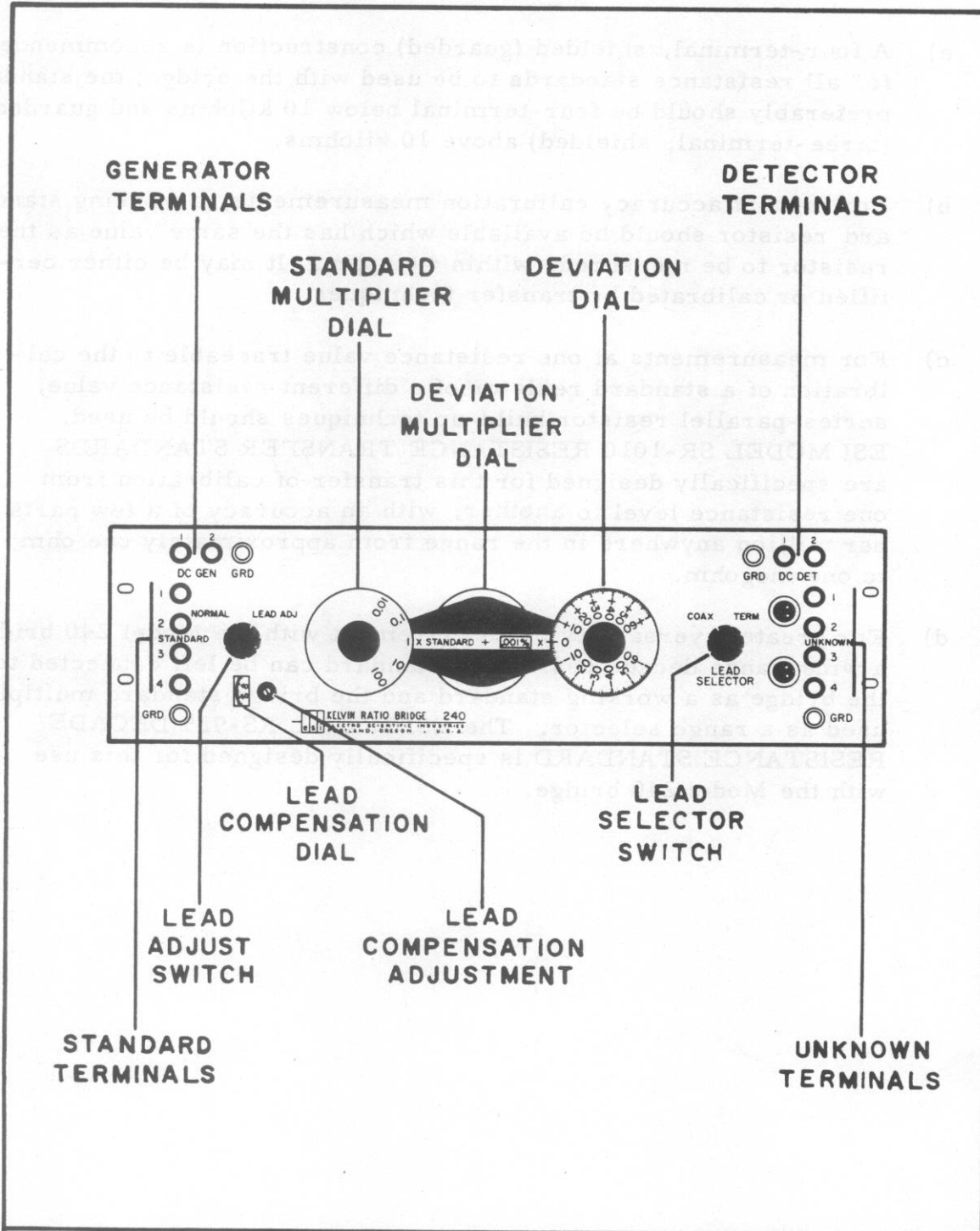

**MODEL 240 KELVIN RATIO BRIDGE
 PANEL CONTROLS**

SECTION II

OPERATING INSTRUCTIONS

2.1 CONTROLS, INDICATORS, AND TERMINALS

Standard Multiplier Dial: The left-hand dial selects from one of five multiplying factors which can be used to compare resistors in the ratios; 1:100, 1:10, 1:1, 10:1, or 100:1. The multiplying factor appears to the left of the words X STANDARD.

Deviation Multiplier Dial: The center dial selects one of three deviation multipliers: 1 ppm, .001%, or .01%. The selected multiplying factor appears in a window to the left of the deviation dial.

Deviation Dial: The right-hand dial times the Deviation Multiplier gives the percent or ppm deviation of the unknown from the product of the standard and the standard multiplier.

LEAD ADJUST Switch: The switch on the left side of the bridge selects either the bridge circuit used for normal operation or that used for adjusting the lead compensator.

Lead Compensation Adjustment: The screw driver control on the left side of the bridge adjusts the circuit to compensate for test lead resistance. The associated dial indicates the approximate test lead resistance in milliohms.

LEAD SELECTOR Switch: The switch on the right-hand side of the bridge selects the unknown terminals. In the COAX position terminals 1 and 4 are connected to the shielded connectors. In the TERM position terminals 1 and 4 are connected to the binding posts. Terminals 2 and 3 are always connected to both the shielded connectors and the binding posts.

DC GEN Terminals: The upper left terminals of the bridge are for attaching an external generator.

DC DET Terminals: The upper right terminals are for attachment of an external detector. In normal bridge operation the number one detector terminal is connected to ground either at this set of terminals or at the detector.

STANDARD Terminals: The terminals along the left-hand side of the bridge are for connection to a four-terminal resistance standard. The adjacent GRD terminal is provided for shield connection.

UNKNOWN Terminals: The terminals along the right-hand side of the bridge are for connection to the resistor to be measured. Shielded connectors are provided for use with ESI Kelvin Klip test leads. Binding post terminals are provided for use with four separate test leads. Since terminals 2 and 3 are permanently connected to the shielded connectors, the LEAD ADJ switch can be set to TERM and the Kelvin Klips used for the number 2 and 3 terminal connections with two wires brought out from terminals UNKNOWN 1 and 4.

2.2 BASIC OPERATING PROCEDURE

The MODEL 240 KELVIN BRIDGE is factory calibrated for better than rated accuracy under laboratory conditions. For maximum accuracy an ambient temperature of 25°C and a relative humidity of less than 50% should be maintained. The power input to the bridge should be reduced to one-tenth maximum power or less if adequate detector sensitivity is available.

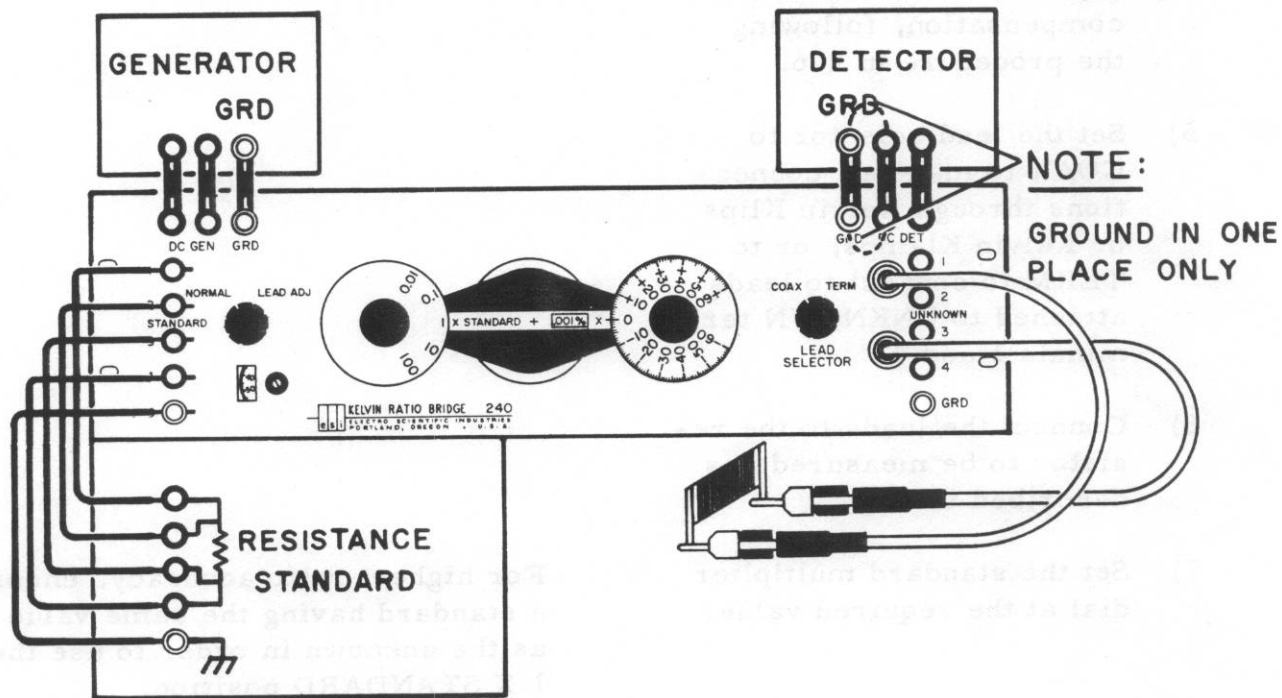

FIG. 2.2

- 1) See that the generator and detector are connected to the bridge as specified in 2.4.
- 2) Connect a suitable fixed or variable standard resistor to the STANDARD terminals of the bridge as described in 2.5.

WARNING: Limit the generator to one watt maximum; ESI generator models feature internal power limiting.

For maximum versatility, a wide-range decade standard such as the ESI Model RS-925 can be left connected as a working standard for practically all measurements.

- 3) Connect the UNKNOWN test leads to the bridge as described in 2.5. For two-terminal resistors, use Kelvin Klips or Kelvin Klamp sets. For four-terminal resistors, use separate leads to UNKNOWN terminals 1 and 4, together with either the Kelvin Klip leads or separate leads to UNKNOWN 2 and 3.
- 4) If the leads for UNKNOWN terminals 2 and 3 are different from those last used, adjust the lead resistance compensation, following the procedure in 2.6.
- 5) Set the lead selector to COAX to make all connections through Kelvin Klips or Kelvin Klamps, or to TERM to connect to leads attached to UNKNOWN terminals 1 and 4.
- 6) Connect the leads to the resistor to be measured, as described in 2.5.
- 7) Set the standard multiplier dial at the required value. For highest ratio accuracy, choose a standard having the same value as the unknown in order to use the 1 X STANDARD position.
- 8) Set the detector sensitivity to an appropriate initial value, and adjust its zero adjustment if the indication is not near zero. Do not short-circuit or open-circuit detector input when making its zero adjustment.
- 9) Turn on the generator. Use low power for the initial balance.
- 10) a. If the standard resistor is fixed, or adjusted to a preset value, adjust the deviation dial and deviation multiplier for a detector null.

- b. If the value of the unknown is to be read on a calibrated adjustable standard resistor, set the deviation multiplier at 1 ppm and the deviation dial at 0, and adjust the standard resistor for a detector null.
- 11) As the null is approached, increase detector sensitivity and/or generator power as required. When detector sensitivity is increased, turn off generator and recheck detector zero adjustment.
12. Continue to adjust deviation dial or standard resistor until detector indication is the same with generator on and off, after any initial detector transient due to reactance has passed. If this detector transient is too large, short the detector momentarily each time the generator is turned on or off; do not disconnect the detector or the unknown, as any thermal or electrolytic voltages present must remain the same with generator on and off.
13. If operating near maximum power rating of bridge, standard or unknown, do not leave generator on long enough to cause drift due to resistor heating. For maximum sensitivity at final balance, make on time as short as possible and increase power as far as possible without causing observable drift due to heating (and without causing permanent change or damage to resistors).

2.3.1 TRACEABLE RESISTANCE CALIBRATION

In precision resistance measurement, the calibration of any resistor must be traceable through a succession of precise resistance comparisons to the unit of resistance maintained as a national or international standard. The resolution and short-term stability of the Model 240 bridge make it possible to compare two like resistance values to an accuracy better than two parts per million.

A standard resistor can be compared with a parallel-connected group of resistors yielding the same resistance value. The same group of resistors can then be connected in series to provide a calibrated standard of a different resistance value. ESI Model SR 1010 Resistance Transfer Standards are designed to make this series-parallel transfer with negligible loss in accuracy. The use of a set of Model SR 1010 transfer standards with the Model 240 bridge will permit calibration of resistors from an ohm to a megohm with an accuracy of a few parts per million, relative to a Thomas pattern one-ohm reference standard certified by the National Bureau of Standards.

The comparison of like resistance values required for this type of calibration can be made independent of the absolute accuracy and long-term stability of the bridge ratio by using either of the two methods described in the following sections.

2.3.2 RESISTANCE COMPARISON BY THE INTERCHANGE METHOD

In the comparison of two nominally equal resistors by the interchange method, the calculated deviation from the standard resistor of the unknown resistor will normally be accurate to within one or two ppm for resistors matched within 60 ppm.

Follow the basic procedure of Section 2.2 to perform the following pair of measurements:

- 1) With the known resistor connected to the STANDARD terminals and the unknown resistor connected to the UNKNOWN terminals, balance the bridge and read the deviation dial. Call this reading d_1 .

- 2) With the unknown resistor connected to the STANDARD terminals and the known resistor connected to the UNKNOWN terminals, balance the bridge and read the deviation dial. Call this reading d_2 .
- 3) Calculate $\frac{d_1 - d_2}{2}$. This is the deviation of the unknown resistor from the standard resistor. To obtain the deviation of the unknown resistor from nominal value, add to this calculated value the deviation of the standard resistor from nominal value.

2.3.3 RESISTANCE COMPARISON BY THE SUBSTITUTION METHOD

In the comparison of two nominally equal resistors by the substitution method, a working standard resistor is left connected to the STANDARD terminals of the ratio bridge while two measurements are made -- one with an accurately known resistor connected to the UNKNOWN terminals, the other with the unknown resistor connected to them.

This method is particularly convenient when a decade standard such as the ESI Model RS-925 is used, since it makes possible direct dial readings corrected to agree with the calibration of the known resistor and expressed either in ohms or in ppm deviation from the nominal value.

This method is based on the fact that either the deviation dial or the decade standard can be used as a calibration adjustment to make the other one read exactly the value of a known resistor connected to the unknown terminals; with the reading exactly correct at this setting, it will be correct within one or two ppm at all nearby settings (to at least ± 60 ppm).

Follow the basic procedure of Section 2.2 to perform either of the following pairs of measurements:

a) To read value in ohms:

1. With the known resistor connected to the unknown terminals, set the decade standard to its given resistance value, then use the deviation dial to balance the bridge.
2. Disconnect the known resistor and connect the unknown resistor.

5. Leaving the deviation dial setting alone, use the decade standard adjustment to balance the bridge. Its reading will be the value of the unknown resistor.

b) To read deviation from nominal value:

1. With the known resistor connected to the unknown terminals, set the deviation dial to its given deviation from nominal value, then use the decade standard dials to balance the bridge.
2. Disconnect the known resistor and connect the unknown resistor.
3. Leaving the decade standard setting alone, use the deviation dial to balance the bridge. Its reading will be the deviation of the unknown resistor from nominal value.

2.3.4 COMPARISON OF LOW RESISTANCE VALUES

When the values of the standard and unknown resistors are so low that the voltage drop in the "yoke" circuit connecting them in series becomes an appreciable fraction of the sum of the voltage drops in the standard and the unknown resistors, the accuracy of the "yoke" or "auxiliary" ratio in the comparison bridge becomes important (refer to Theory Section 3.6). The accuracy of the auxiliary ratio in the Model 240 bridge is such that this effect can be neglected for resistance values of an ohm or higher, unless the yoke resistance is unusually high.

When the auxiliary ratio accuracy cannot be neglected, the ratio can be adjusted to exactly match the main ratio by adding a small amount of resistance in series with the UNKNOWN 3 or STANDARD 3 terminal. This resistance should be adjusted so that the bridge remains balanced when the lead at either UNKNOWN 4 or STANDARD 4 is disconnected and reconnected.

The need for this adjustment can be minimized in some instances by making an external yoke connection of lower resistance, as discussed in Section 2.5.3 on measurements at high current. The effect of auxiliary ratio accuracy also becomes relatively unimportant in either the interchange method (Section 2.3.2) or the substitution method (Section 2.3.3) of comparing two equal resistors if the yoke resistance can be made the same for both measurements -- in this case both readings will be affected the same amount by any inaccuracy in the auxiliary ratio, and the error will be cancelled.

2.4 GENERATOR-DETECTOR CONNECTIONS

The Model 240 Bridge is designed for use with a grounded detector having a fixed input resistance, and a floating generator or set of batteries providing a wide range of voltages and currents. The normal connections described in the following sections are suitable for all normal bridge applications. They give the bridge its full accuracy over a very wide range of resistance from low value four-terminal resistors to high value guarded or three-terminal resistors. The alternate connections described in Section 2.4.3 are for certain specific situations and should not be used for general purpose use of the bridge.

2.4.1 NORMAL GENERATOR CONNECTIONS

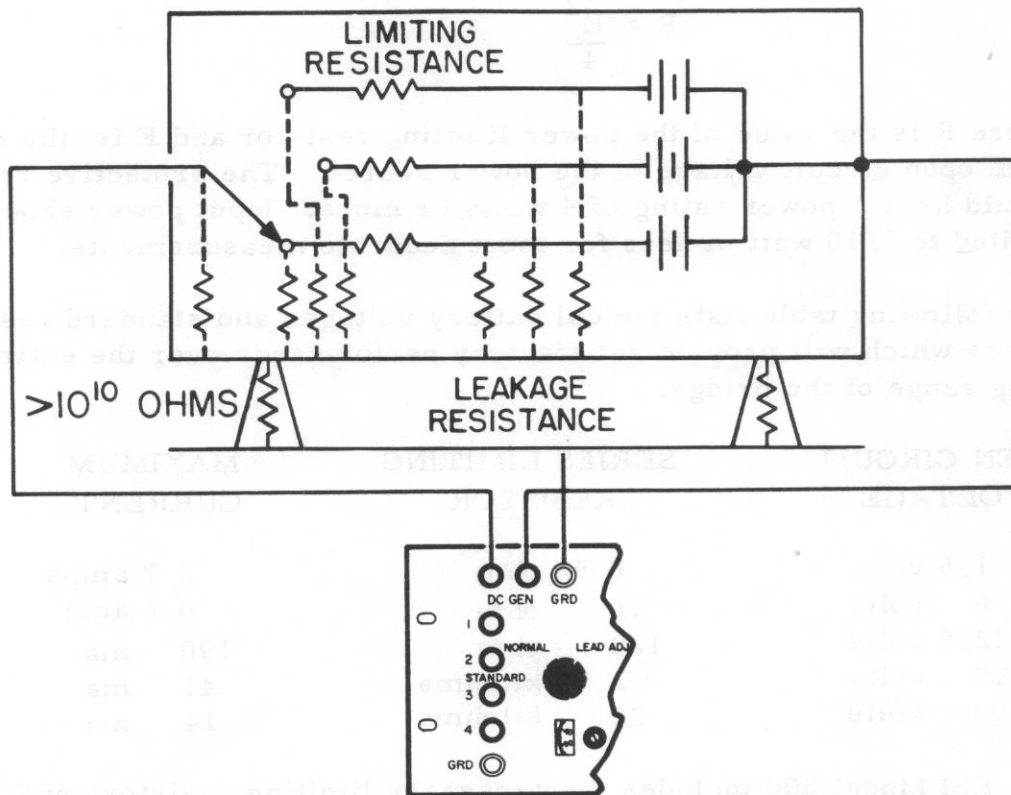

FIG. 2.4.1

For high resistance measurements the DET 1 terminal of the bridge must be grounded, requiring that the generator be well isolated from ground (see Fig. 2.4.1). The leakage resistance from GEN 2 to ground will then appear across a 10 kilohm arm of the bridge where a leakage resistance of 10^{10} ohms will cause a ratio error of only 1 ppm. Any

leakage resistance from the GEN 1 terminal to ground will appear across the range resistor which is 1 megohm at the highest range.

In some installations the ambient humidity may make it difficult to maintain bridge dependability without guarding. Therefore, it is recommended that the generator or battery be mounted so that all leakage paths through insulating materials return to a guard chassis which is connected to the GEN 2 terminal. Then these leakage resistances will not appear in the measurement. Neither will there be any leakage from GEN 1 to ground, external to the bridge.

For bridge protection and reliability it is necessary that the maximum available power to the bridge be limited to one watt. This is accomplished by placing a resistor in series with the power source. The value of this resistor can be calculated from the formula

$$R = \frac{E^2}{4}$$

where R is the value of the power limiting resistor and E is the maximum open circuit voltage of the power source. The protective resistor should have a power rating of 4 watts or more. Input power should be limited to 1/10 watt or less for most accurate measurements.

The following table lists typical battery voltages and standard resistor values which will provide satisfactory performance over the entire operating range of the bridge.

OPEN CIRCUIT VOLTAGE	SERIES LIMITING RESISTOR	MAXIMUM CURRENT
1.5 volts	0.56 ohm	2.7 amps
6 volts	10 ohm	0.6 amp
22.5 volts	120 ohm	190 ma
90 volts	2.2 kilohms	41 ma
300 volts	22 kilohms	14 ma

The ESI Model 800 includes the necessary limiting resistors and has a variable output power control. It is also guarded and is recommended for use with the 240 bridge.

2.4.2 NORMAL DETECTOR CONNECTION

For normal Model 240 Kelvin Ratio Bridge applications, it is suitable to connect the low or grounded input terminal to the detector to DET 1 and the sensitive or high input to DET 2. If the detector is sensitive to interference from ac pickup, the lead from DET 2 should be shielded.

It is advisable that the bridge always be grounded rather than floating. If the bridge is floating it is very difficult to determine what the effects of the leakage resistances are on the measurement. By proper grounding, however, the effects not only can be determined but minimized as well. Generally, the DET 1 terminal is the most desirable corner of the bridge to have grounded.

While it is important that the bridge be grounded, it is equally important that it be grounded at one point only. Multiple grounds are very likely to cause errors due to ground loop currents. If the detector is internally grounded be sure there is no other ground connection. If one of the detector leads is shielded its shield may be used either to carry the grounded side of a signal current or to connect two chassis together, but not both -- separate conductors must be used for the two connections.

2.4.3 ALTERNATE DETECTOR CONNECTION

When the detector used is not internally grounded, it is possible to reduce the sensitivity of the test leads to stray electrostatic pickup, for measurements in which the standard resistor is lower than 10 kilohms, by using the alternate detector connection of Fig. 2.4.2. Since this alternate connection places leakage resistances in parallel with the standard and unknown resistors, rather than internal ratio arms, it should not be used where the standard resistor is greater than 10 kilohms.

Connect the sensitive detector input to DET 1.

Connect the low detector input to DET 2.

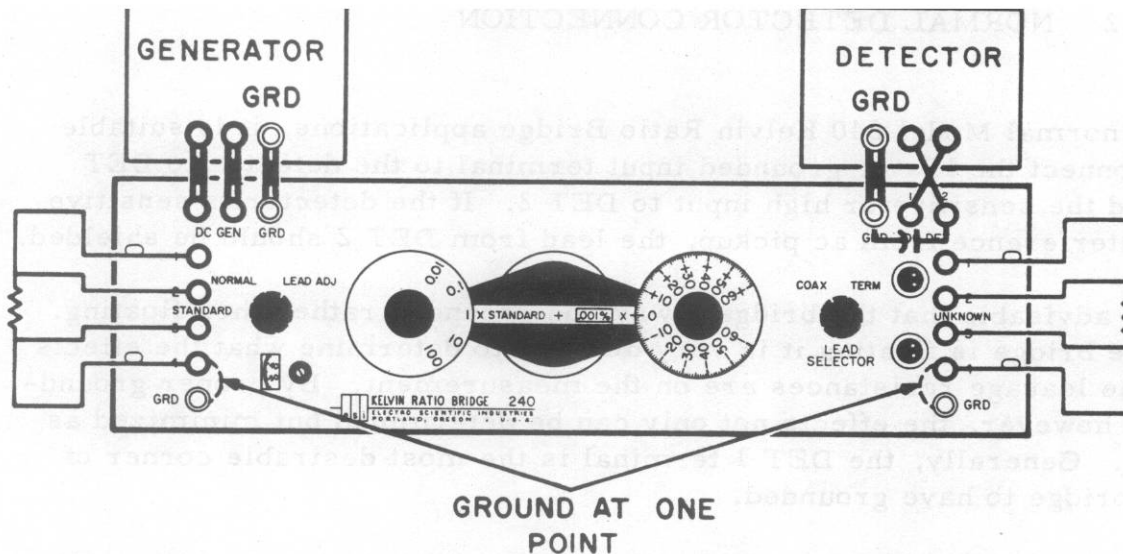

FIG. 2.4.3

Connect a large capacitor from DET 2 to GRD if the low detector input is not already well by-passed internally.

Connect terminal 4 of either the UNKNOWN or STANDARD side to the adjacent GRD.

Be careful that there is no dc connection from this lead to ground, as this would short the yoke ratio, converting it to a single ratio bridge, producing errors due to lead resistance.

2.4.4 GENERATOR-DETECTOR INTERCHANGE

For comparing two resistors having a very high resistance value, a higher voltage can be applied to the standard and unknown resistors, and the bridge sensitivity thereby increased, by interchanging the generator and the detector. This connection may also be useful in other applications where it is desirable to have the same voltage applied to the standard and the unknown; the usual connection makes their

currents the same; on ranges higher or lower than 1 X STANDARD, the relative power dissipated by the standard and the unknown will be interchanged by the generator-detector interchange. (The normal connection applies the greater power to the larger resistance. The interchanged connection applies the greater power to the smaller resistance.)

If the detector used is sufficiently insulated from ground, the generator lead connected to the DET 2 terminal of the bridge should be grounded (see Section 1.3.2, paragraph c 2). However, if the detector is designed to operate with one of its terminals grounded the generator must be floated. Which GEN terminal should be connected to the grounded detector lead will depend on the multiplier used.

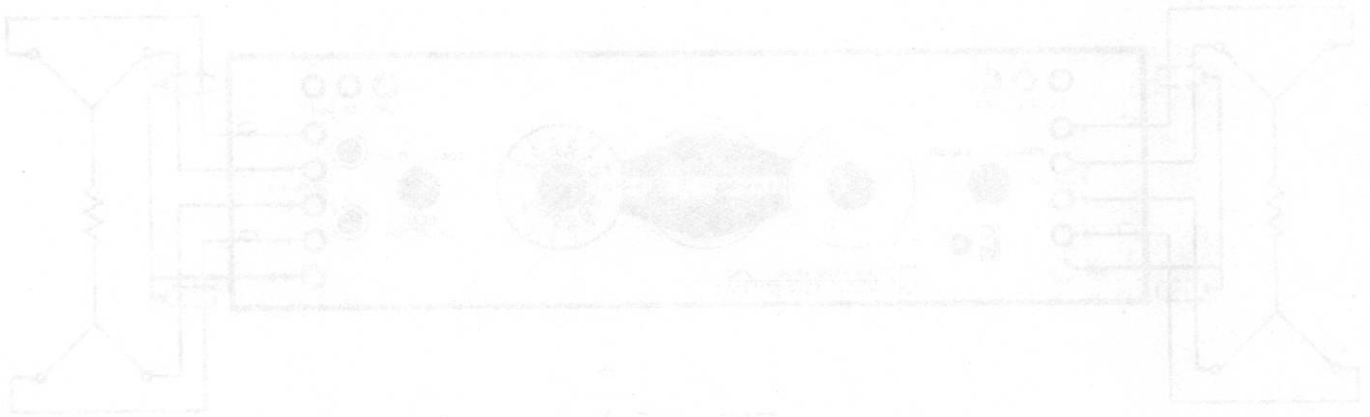

FIG. 1.5.1

If a shield is used, the shield leads should be connected to the detector and standard terminals. The shield should be connected to the bridge ground. This will prevent leakage between the leads. The shield should be connected to the standard or unknown terminal, whichever is used. Leakage between terminals 1 and 2, or 3 and 4 will not affect the measurement, but leakage between 1 and 3, or 2 and 4 will. However, leakage between the shield leads and the shield will appear as a leakage between the standard and the unknown terminals. It is necessary that the leads be adequately insulated from the shield. A shielded cable is recommended for this application.

In using the standard and unknown resistors it is necessary to consider the effect of the lead resistance. The resistance of the lead connected to terminal 1 on both the standard and unknown sides will affect the measurement. The generator and detector will not affect the

2.5.1 BASIC CONNECTIONS

The 240 bridge is designed for making four-terminal connections to the standard and unknown resistors. On the standard side four binding posts are provided for four separate leads to the standard resistor. Binding posts are also provided on the unknown side as are shielded connectors for using two shielded pairs of wires. On each side the leads from terminals 1 and 2 are to be connected to one end of the resistor and the leads from terminals 3 and 4 to the other end, as shown in Fig. 2.5.1.

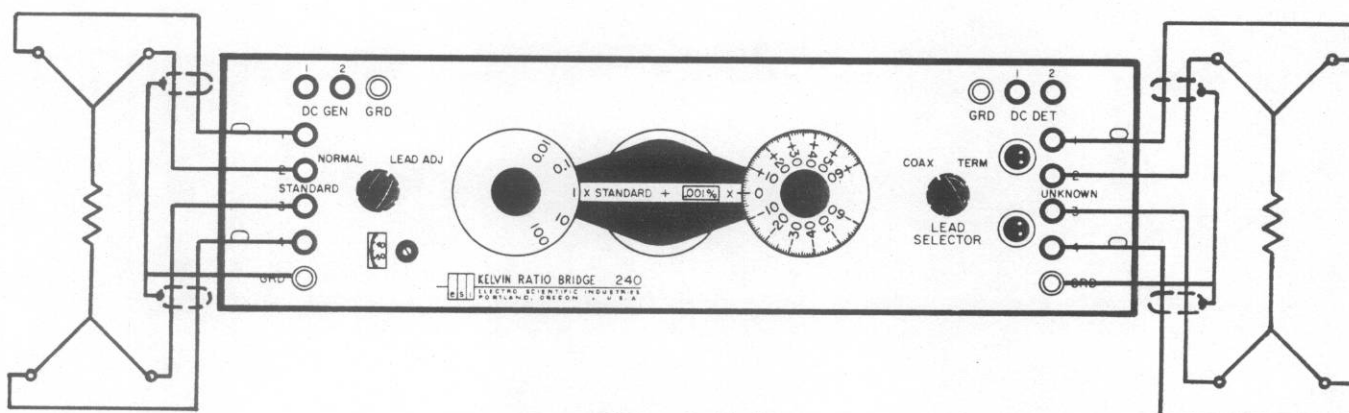

FIG. 2.5.1

It is advisable to use shielded leads for connecting to the unknown and standard resistors. The shields should be connected to the bridge ground. This not only prevents leakage between the leads from appearing in shunt with the standard or unknown resistor, it also reduces ac pickup which may be a problem when an electronic detector is used. Since leakage between terminals 1 and 2, or 3 and 4 will not affect the measurement each pair may be enclosed in the same shield. However, leakage between the enclosed leads and the shield will appear across internal bridge arms, thus it is necessary that the leads be adequately insulated from the shield. ESI KELVIN KLIPS (four-terminal connectors) or Belden 8422 cable is recommended for this application.

In connecting the standard and unknown resistors it is necessary to consider the effects of the lead resistances. The resistance of the lead connected to terminal 1 on both the standard and unknown side of the bridge is in series with the generator and will not affect the

measurement accuracy. The resistance of the lead connected to terminal STANDARD 2 appears in series with a 10 kilohm bridge arm. This will cause a 1 ppm ratio error for each 10 milliohms of lead resistance. On the unknown side the lead compensation adjustment makes it possible to compensate for lead resistances under 100 milliohms in series with UNKNOWN 2 and 3. Lead resistance in series with terminals STANDARD 3 and 4, and UNKNOWN 3 and 4 will not be critical except for low valued resistance measurements, see Sections 2.3.4 and 3.6. When making low valued resistance measurements the connections shown in Fig. 2.5.4 should be used to reduce the yoke resistance. The yoke resistance as referred to throughout this manual is the resistance between terminal STANDARD 4 and UNKNOWN 4 plus the resistance of the leads connected to these two terminals, including the leads inside four-terminal standard and unknown resistors.

As an alternate connection for high resistance measurements, where the Kelvin bridge advantages are not needed, the pair of leads to each end of each resistor may be replaced by a single lead, and terminal 1 connected to 2, and 3 connected to 4, at the bridge. There is normally little need for this connection, however, since the Kelvin Klip leads or other test lead pairs used for low resistance measurements can be used equally well for high resistance measurements.

2.5.2 GUARDED UNKNOWN AND STANDARD RESISTOR CONNECTIONS

The 240 is so designed that internal leakages will not appear in shunt with either the resistor under test or the standard. This makes it possible to measure very high resistance. However, it is necessary that the resistor under test is not subject to external leakage effects. When a resistor is mounted between two terminals on an insulating block, the leakage of the block shunts the resistor. When separate insulators are mounted on a conducting support, however, as illustrated in Fig. 2.5.2a, the leakages can be separated from the resistor.

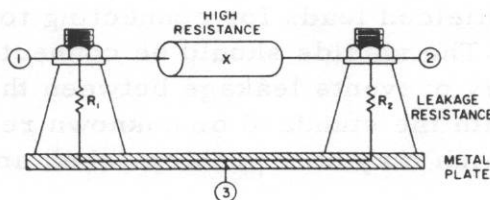

FIG. 2.5.2a

When the third terminal (the case or mounting plate) is connected to the Kelvin bridge as shown in Fig. 2.5.2b the leakages are placed across other arms of the bridge circuit. Leakage resistances R_2 and R_4

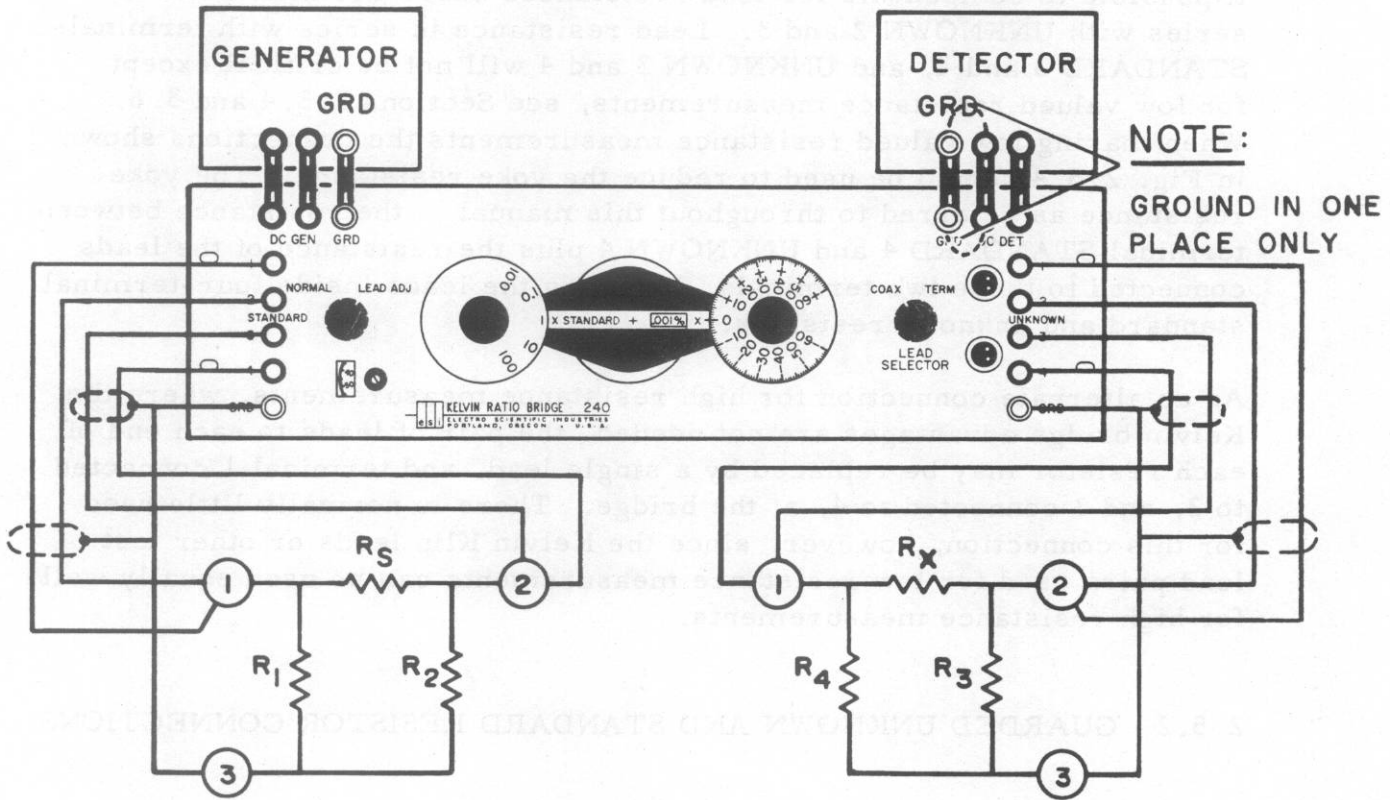

FIG. 2.5.2b

are essentially across the detector and will cause no error. Leakage resistance R_1 , will be across a 10 kilohm internal bridge arm. This means R_1 must be greater than 10^{10} ohms before it can be considered as causing a negligible error (less than 1 ppm). Leakage resistance R_3 must be greater than 10^{10} ohms times the standard multiplier setting to have a negligible effect.

When making high resistance measurements with the 240 bridge it is advisable to use shielded leads for connecting to the unknown and standard resistors. The shields should be connected to the bridge ground. This not only prevents leakage between the leads from appearing in shunt with the standard or unknown resistor, it also reduces ac pickup which may be a problem when an electronic detector is used.

2.5.3 CONNECTIONS FOR RESISTANCE MEASUREMENTS AT HIGH CURRENT

To measure low valued resistors using a high current, an external current loop should be formed as shown in Fig. 2.5.3. This method will also permit a lower yoke resistance to be used than that internal to the bridge.

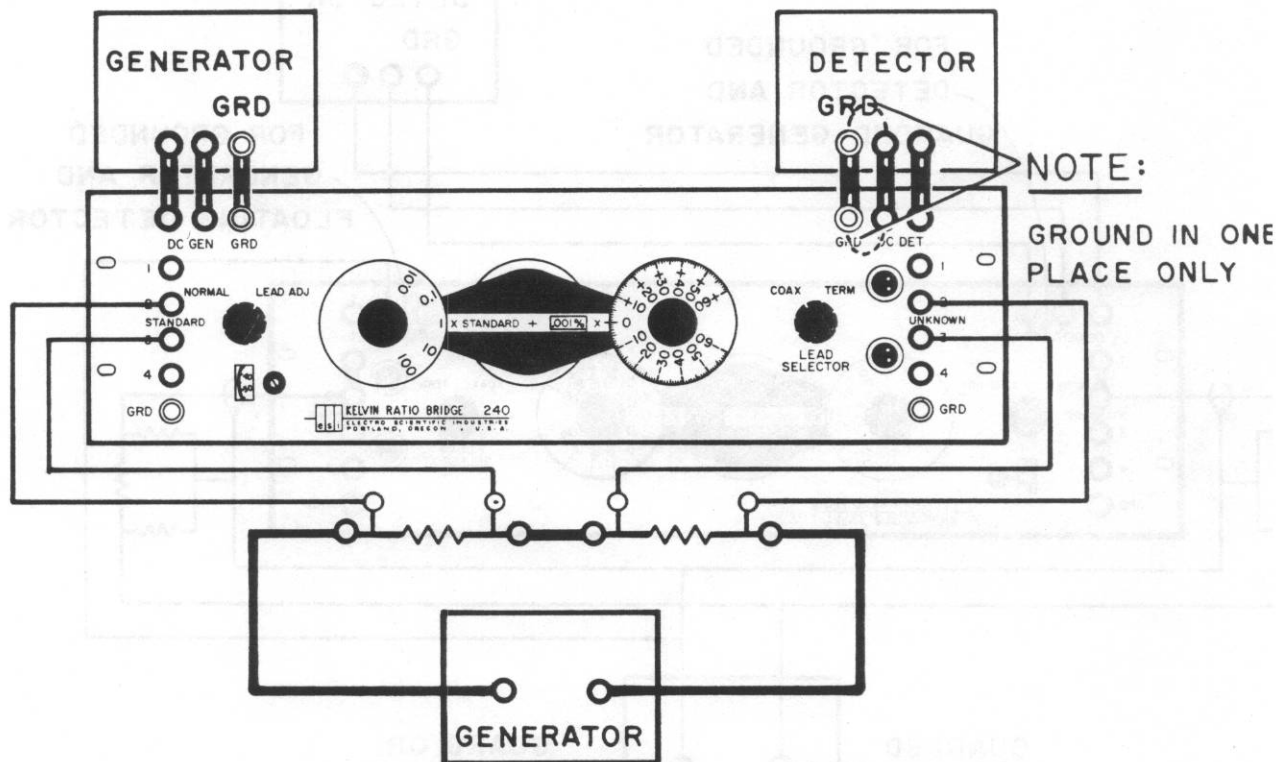

FIG. 2.5.3

2.5.4 CONNECTIONS FOR RESISTANCE MEASUREMENTS AT HIGH VOLTAGE

To measure high valued resistors at voltages high enough that they could cause break down in the bridge (1000 volts or more) or where it is desired to have equal voltage across the standard and unknown resistors instead of equal current, the connections shown in Fig. 2.5.4 should be used. (The connections shown are for three-terminal resistors.) It is necessary to have either a high-voltage power supply

which is of completely guarded construction as described in Section 2.4.1 (the guarded terminal being the one connected to the junction of the unknown and standard) or a detector which can be isolated from ground as discussed in Sections 2.4.4 and 1.3.2.

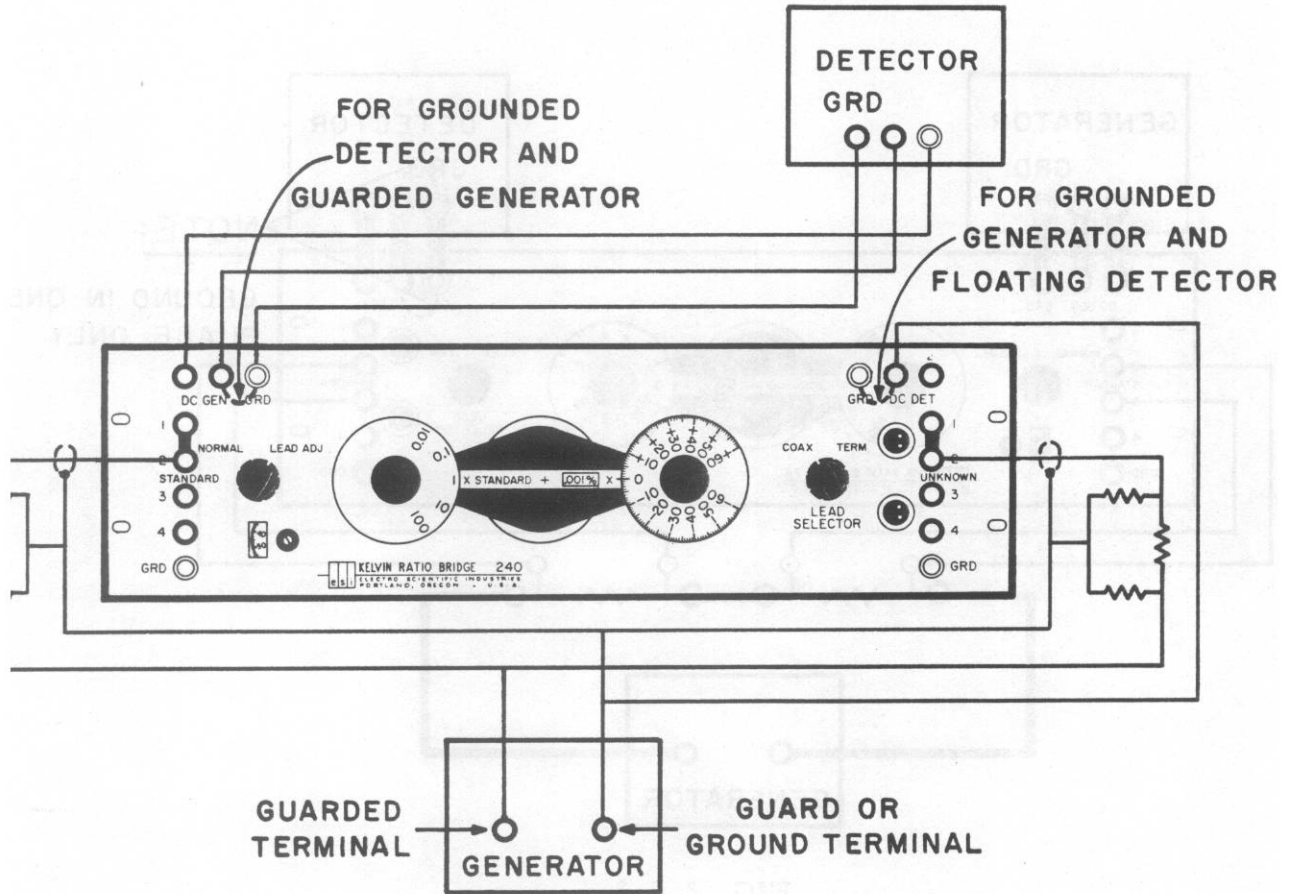

FIG. 2.5.4

2.6 LEAD RESISTANCE COMPENSATION ADJUSTMENT

2.6.1 GENERAL

When a four-terminal connection is made to the unknown resistor, the resistance of the test leads from UNKNOWN 2 and 3 appears in series with bridge arms of moderately high value, minimizing their effect. Since the effect is not always negligible, the bridge arms have been made adjustable over a small range to allow compensation.

The bridge arm resistance is 10 kilohms times the standard multiplier setting. Therefore, the lead compensation adjustment becomes increasingly critical at lower standard multiplier settings, 1 ppm divided by the multiplier setting corresponds to 10 milliohms of lead resistance.

When the lead adjustment switch is set to LEAD ADJ, the bridge circuit is changed as shown in Figure 2.6.1. This circuit measures the total resistance of the UNKNOWN 2 bridge arm to the end of its lead, with the bridge arm resistance at its lowest and most critical value. The screwdriver adjustment is used to adjust this arm for a bridge balance; its dial indicates the approximate number of milliohms in the UNKNOWN 2 test lead. A ganged adjustment simultaneously sets another rheostat which will make the UNKNOWN 3 arm the same value after the switch is returned to the NORMAL operating position; this assumes that the UNKNOWN 2 and 3 test leads will be approximately matched in resistance (will be of the same length and wire size).

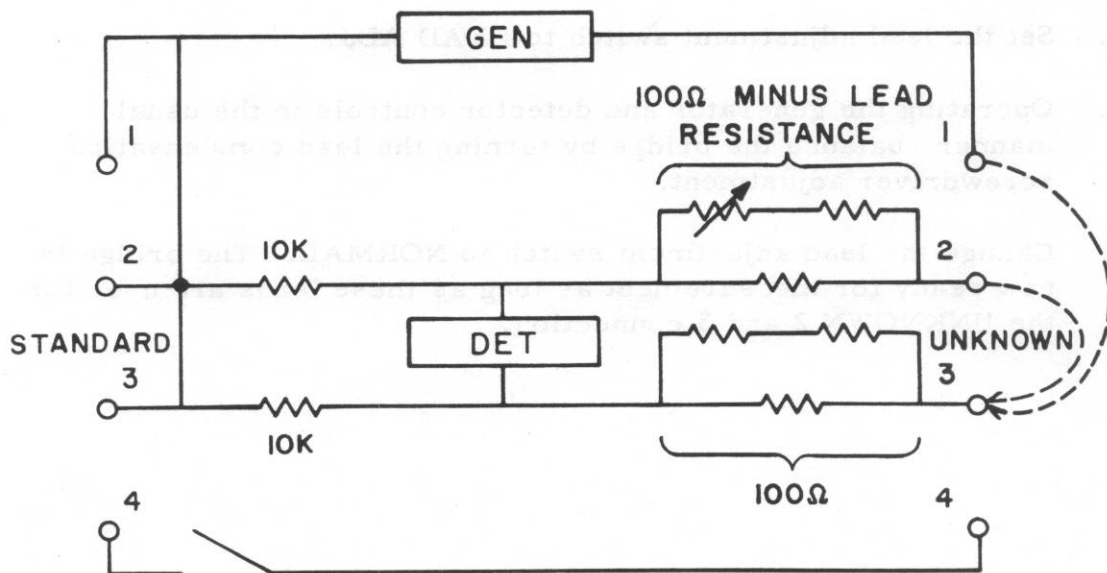

FIG. 2.6.1

2.6.6 LEAD ADJUSTMENT WITH KELVIN KLIP LEADS

The following adjustment compensates for the resistance of Kelvin Klip test leads. The adjustment will be correct both for use of the Kelvin Klip leads alone, and for use of the Kelvin Klip leads for the UNKNOWN 2 and 3 connections together with separate leads from UNKNOWN 1 and 4.

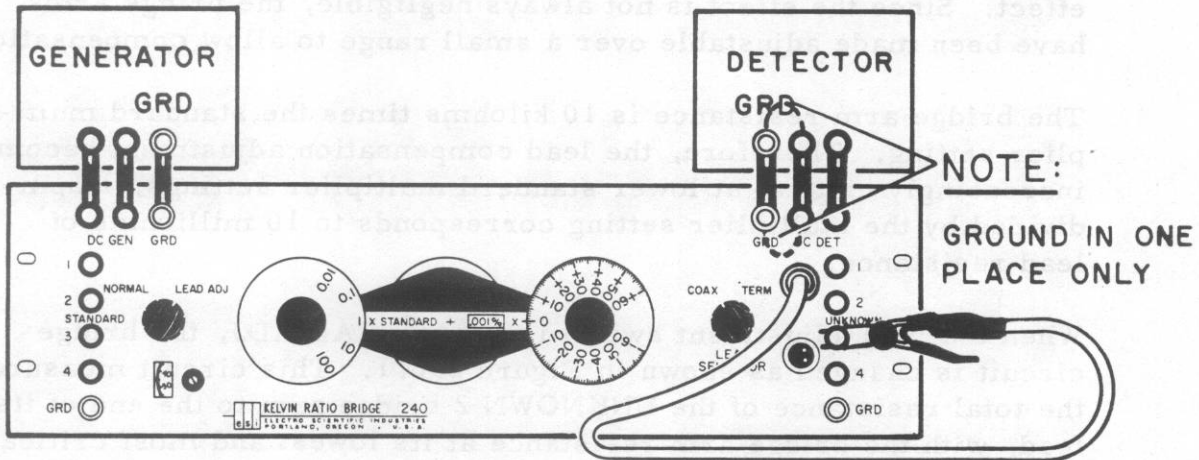

FIG. 2.6.2

1. Connect the Kelvin Klip from the upper lead to UNKNOWN 3, as shown in Fig. 2.6.2.
2. Set the lead selector to COAX.
3. Set the lead adjustment switch to LEAD ADJ.
4. Operating the generator and detector controls in the usual manner, balance the bridge by turning the lead compensation screwdriver adjustment.
5. Change the lead adjustment switch to NORMAL. The bridge is now ready for measurement as long as these leads are used for the UNKNOWN 2 and 3 connection.

2.6.3 LEAD ADJUSTMENT WITH FOUR SEPARATE LEADS

The following procedure compensates the bridge for the resistance of separate test leads connected to terminals UNKNOWN 2 and 3:

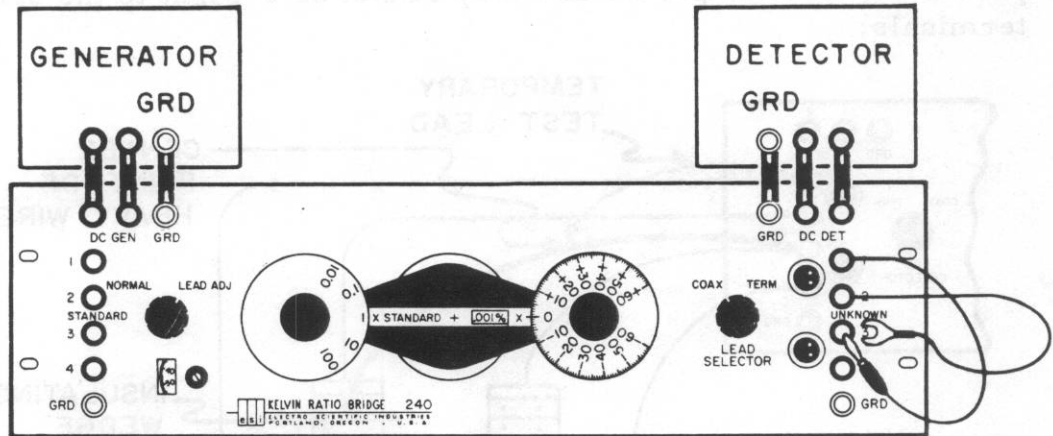

FIG. 2.6.3

1. Connect the outer ends of the UNKNOWN 1 and 2 leads to the UNKNOWN 3 terminal (one in the top and one in the side of the terminal), as shown in Fig. 2.6.3.
2. Set the lead selector to TERM.
3. Set the lead adjustment switch to LEAD ADJ.
4. Operating the generator and detector controls in the normal manner, balance the bridge by turning the lead compensation screwdriver adjustment.
5. Change the lead adjustment switch to NORMAL. The bridge is now ready for measurement as long as the same UNKNOWN 2 lead and an UNKNOWN 3 lead of similar resistance are used.

2.6.4 LEAD ADJUSTMENT WITH END OF LEAD AT A DISTANCE

The following procedure compensates the bridge for the resistance of test leads whose far ends are anchored to a test jig, such as a pair of Kelvin Klamps, so that they cannot be brought to the bridge terminals:

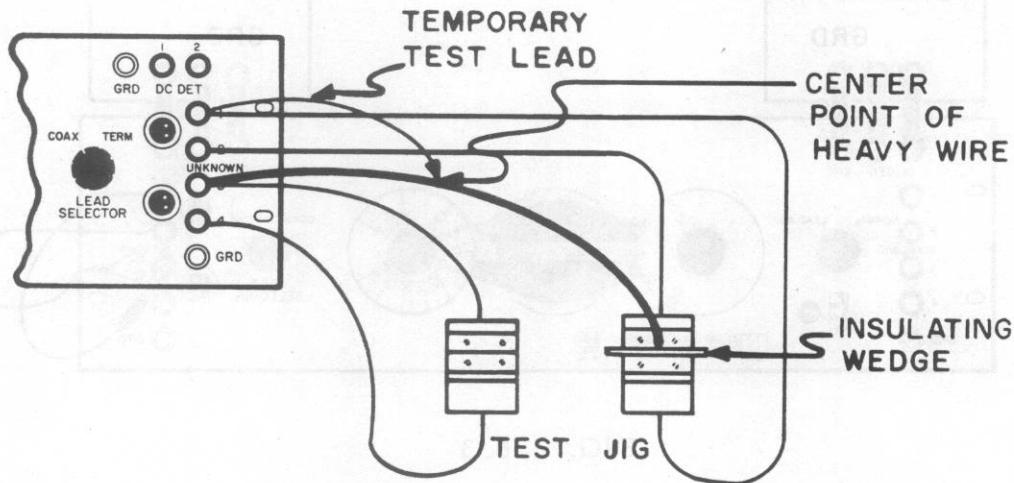

FIG. 2.6.4

1. Bring the end of the UNKNOWN 2 lead as close as practicable to the bridge, then connect its end to UNKNOWN 3 through a short, heavy piece of wire or bus bar, as shown in Fig. 2.6.4.
2. Connect a temporary test lead from the exact center of this heavy wire to UNKNOWN 1 (make sure the outer ends of the UNKNOWN 1 and 2 leads are not connected together for this adjustment).
3. Set the lead selector to TERM.
4. Set the lead adjustment switch to LEAD ADJ.
5. Operating the generator and detector controls in the normal manner, balance the bridge by turning the lead compensation screwdriver adjustment.
6. Remove the heavy wire and the temporary test lead to its center.
7. Change the lead adjustment switch to NORMAL. The bridge is now ready for measurement as long as the same UNKNOWN 2 lead and an UNKNOWN 3 lead of similar resistance are used.

2.6.5 COMPENSATION FOR LEAD RESISTANCE INSIDE A FOUR-TERMINAL RESISTOR

When the unknown to be measured is a four-terminal resistor of a construction having significant resistance from all of its terminals to the internal junction points, the lead adjustment procedure must be modified. The procedure must include first a measurement of the resistance from the internal junction point to the resistor terminal to be connected to the UNKNOWN 2 bridge lead. Then, after following the usual lead adjustment procedure, the lead compensation screwdriver adjustment is changed to increase its dial setting by the number of milliohms of this resistance to be added beyond the end of the UNKNOWN 2 test lead.

This modified procedure need be used only if the added resistance will be greater than 1 part per million of the bridge arm to be connected in series with it, which corresponds to 10 milliohms times the standard multiplier setting to be used.

The internal lead resistance in any four-terminal resistor can be measured by connecting it as shown in Fig. 2.6.5 and following the usual bridge operating procedure.

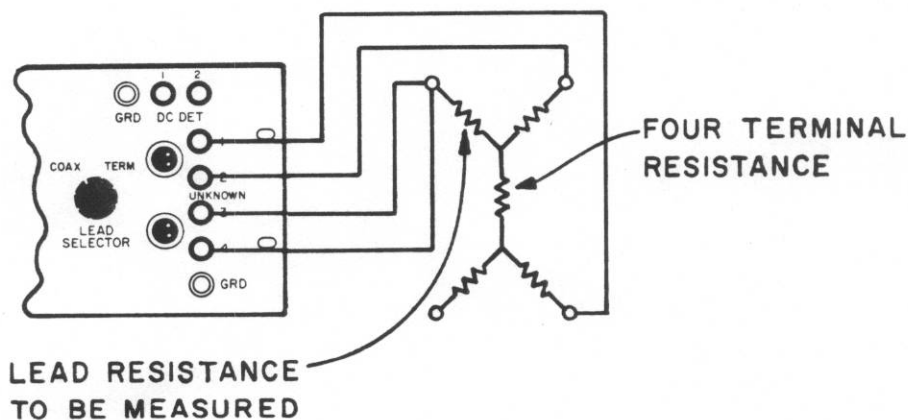

FIG. 2.6.5

FIG. 2. COMPENSATION FOR LEAD RESISTANCE IN THE A FOUR-TERMINAL RESISTOR

When the unknown to be measured is a four-terminal resistor of a constant having its internal resistance (from its terminals) to the internal junction point, the lead adjustment procedure must be modified. The procedure must include first a measurement of the resistance from the internal junction point to the test terminal to be connected to the UKR-OWN 2 bridge lead. Then, after following the usual lead adjustment procedure, the lead compensation factor adjustment is changed to increase its millivolt setting by the number of millivolts of the resistance to be added between the end of the UKR-OWN 2 test lead.

The modified procedure must be used only if the added resistance will be greater than 1 part per million of the other end to be connected in series with it, which corresponds to 10 millivolts times the standard millivolt setting to be used.

The internal lead resistance in a four-terminal resistor can be measured by connecting it as shown in Fig. 2.0.5 and following the usual bridge operating procedure.



FIG. 2.0.5

SECTION III

THEORY OF OPERATION

3.1 GENERAL

The Kelvin double bridge was originally designed for accurately measuring very low-valued resistors. This is not possible with a Wheatstone bridge operated in the normal manner as a result of the uncertainty of the contact resistance to the resistor being measured. Measurements using the Wheatstone bridge can be improved by use of a four-terminal connection to the resistor under test, however, this places one of the connection resistances in series with a bridge arm which must also have a low value for maximum bridge sensitivity. With a Kelvin bridge two low-valued four-terminal bridge arms can be used, yet all connection resistances are made to appear in series with high resistance arms thus causing far less error.

The 240 is a modified Kelvin double bridge. The modifications include a five-range ratio multiplier, a lead resistance compensation adjustment, dials reading deviation from nominal ratio in percent or parts per million, and guarding to make the bridge suitable for high resistance measurements as well as low, see Fig. 3.1. Its schematic circuit diagram is shown in Fig. 5.3.2.

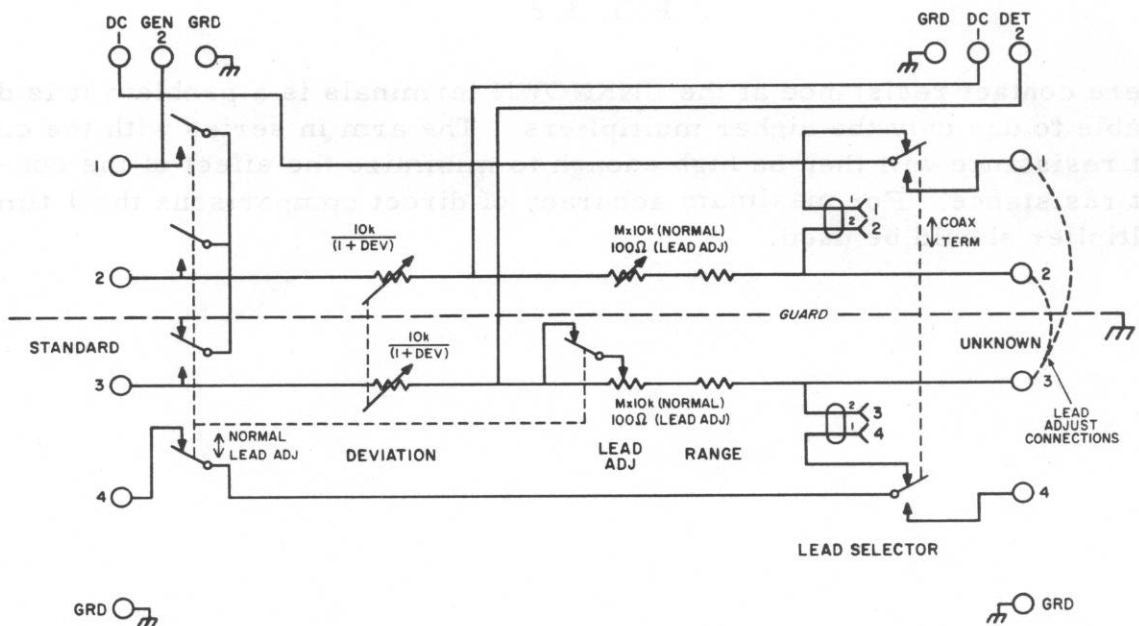

FIG. 3.1

3.2 STANDARD MULTIPLIER RATIOS

The STANDARD MULTIPLIER allows comparison of resistors in the ratios of 0.01:1, 0.1:1, 1:1, 10:1 and 100:1. This is accomplished by changing the ratio arms on the unknown side of the bridge from 100 ohms to 1 megohm while those on the standard side remain at 10 kilohms.

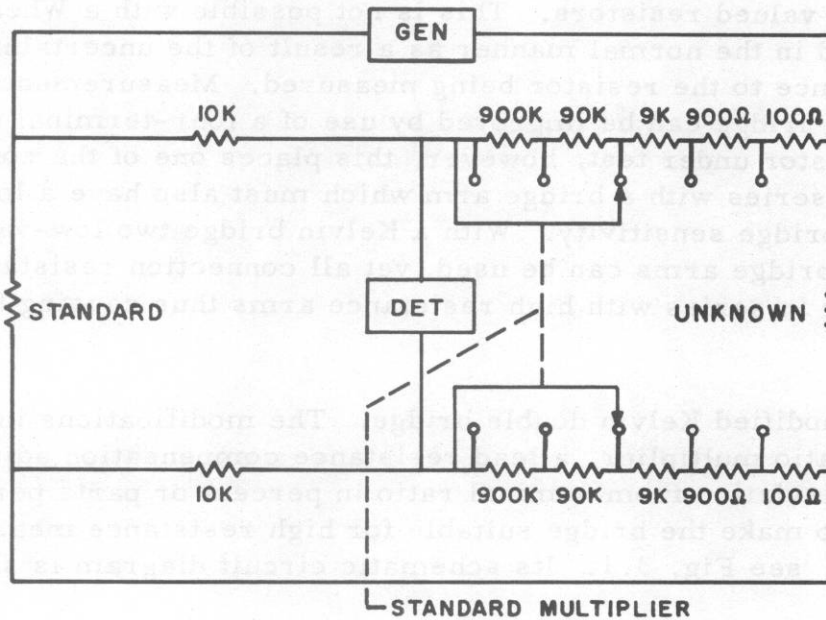

FIG. 3.2

Where contact resistance at the UNKNOWN terminals is a problem it is desirable to use only the higher multipliers. The arm in series with the contact resistance will then be high enough to minimize the effect of the contact resistance. For maximum accuracy of direct comparisons the 1 times multiplier should be used.

3.3 LEAD RESISTANCE COMPENSATION ADJUSTMENT

As more accurate measurements are sought, contact and lead resistances become more significant. Lead resistance is fairly stable and can be corrected or compensated for. In the 240 it is compensated for by adjusting the arm it is in series with. Contact resistance is not usually as stable. What must be done to minimize its effect is to make the contact resistances appear in series with high resistance arms thus swamping out their effect. On the one times range of the 240 the contact resistances will be in series with 10 kilohm bridge arms; on the 0.01 times range it is in series with only 100 ohms. Thus a contact resistance uncertainty of 10 milliohms will cause only a 1 ppm error on the 1 times range which can be neglected for most measurements but will cause a 100 ppm error on the 0.01 times range, which may not be negligible for certain measurements.

When the LEAD SELECTOR switch is in the LEAD ADJ position an internal Wheatstone bridge is formed to measure test lead resistance as shown in Fig. 3.3. One arm of this bridge consists of a variable resistance network in series with the test lead normally connected to terminal UNKNOWN 2; the other three arms are fixed. The lead compensation adjustment is then used to balance the bridge.

Ganged to the lead compensation adjustment is a similar variable resistance network which, in the normal operation of the bridge will be in series with the test lead connected to terminal UNKNOWN 3. It is therefore necessary that the two leads be approximately of equal resistance. The accuracy of the UNKNOWN 3 lead resistance compensation is much less critical than that of UNKNOWN 2, except when measuring resistors of very low value.

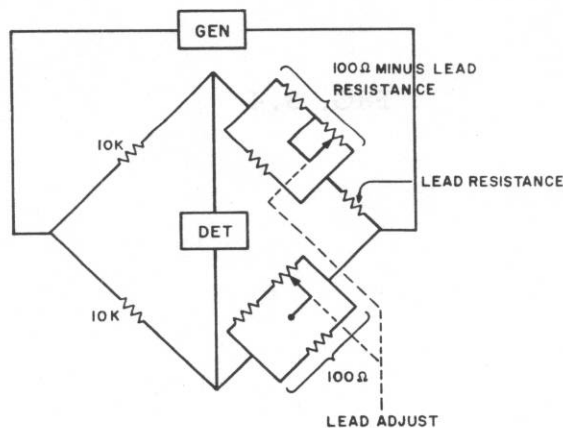

FIG. 3.3

3.4 DEVIATION DIALS

The deviation dials permit comparison between a fixed standard and an unknown resistor directly in percent or ppm deviation. This is accomplished with ganged rheostats varying the 10 kilohm arms on the standard side of the bridge. The conductance ($\frac{1}{R}$) varies from the 10 kilohm nominal value by the percent or ppm indicated on the deviation dials, producing a deviation from the nominal multiplier ratio of the same amount.

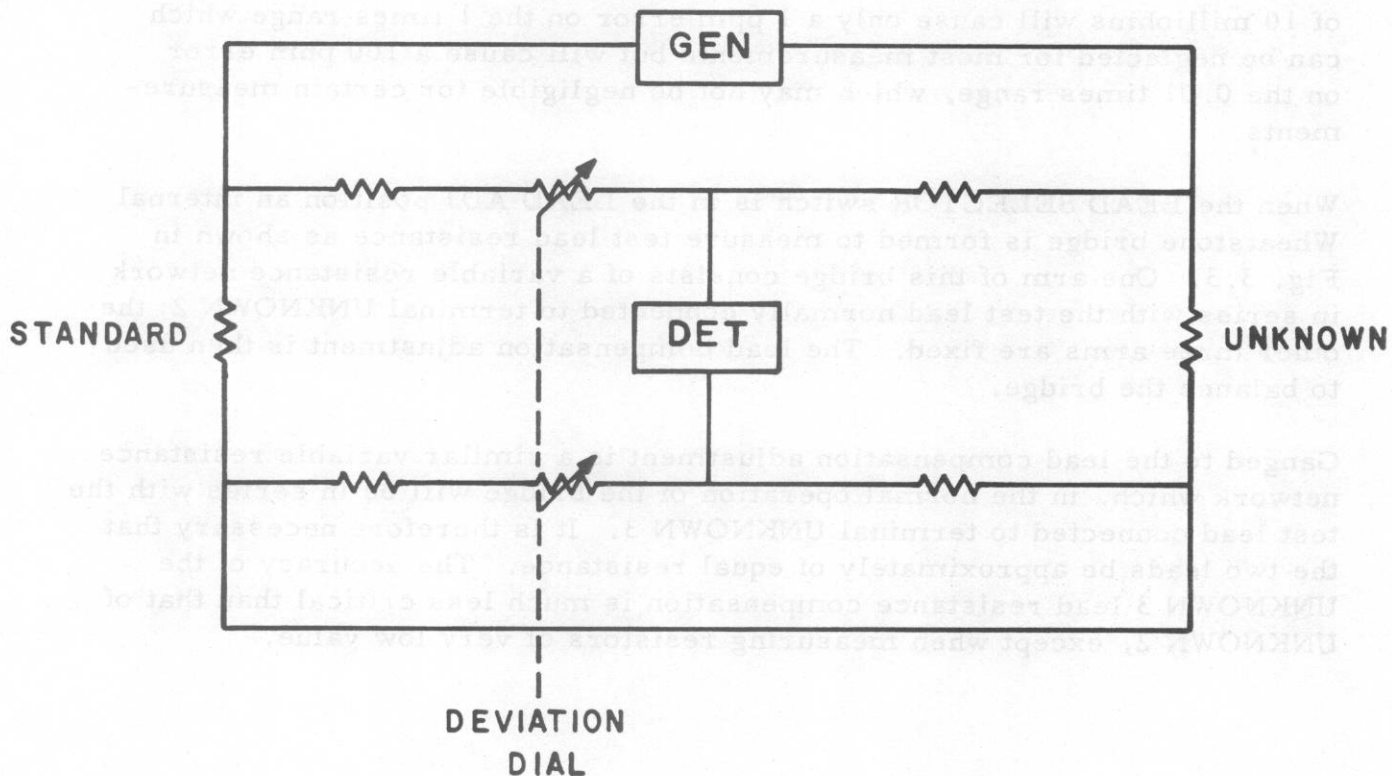

FIG. 3.4

3.5 GUARDING

In order to prevent internal leakage from appearing in shunt with the STANDARD or UNKNOWN terminals no switch deck or insulator is common to the upper two and the lower two STANDARD or UNKNOWN terminals. This allows the 240 to be used as a guarded bridge to measure very high valued resistors. To prevent external leakage from shunting the standard or unknown resistor three terminal connections should be used. See Section 2.5.2 GUARDED UNKNOWN AND STANDARD RESISTOR MEASUREMENTS.

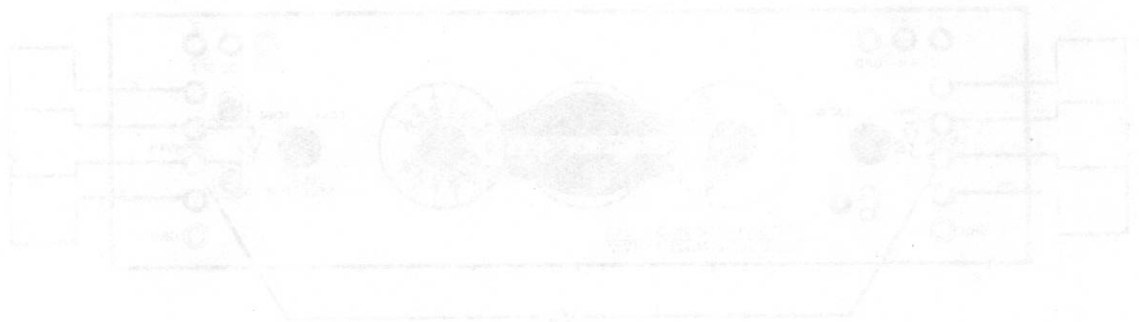

FIG. 3.5

Various factors affecting the accuracy of the main and auxiliary bridge ratios are discussed throughout this manual. The relative importance of main ratio accuracy versus auxiliary ratio accuracy depends upon the resistance of the "yoke" connection between the unknown and standard resistors (through terminal 4 of unknown and standard). The basic accuracy equation is:

$$d_{\text{bridge}} = d_m \left(1 + \frac{V_y}{V_s + V_x}\right) - d_a \left(\frac{V_y}{V_s + V_x}\right)$$

$$= d_m + (d_m - d_a) \left(\frac{V_y}{V_s + V_x}\right)$$

Where:

- d_{bridge} is the resulting bridge ratio error
- d_m is the main ratio error
- d_a is the auxiliary ratio error
- V_s is the standard resistor voltage (STANDARD 2 to STANDARD 3)
- V_x is the unknown resistor voltage (UNKNOWN 2 to UNKNOWN 3)
- V_y is the yoke voltage drop, including that inside the four-terminal standard and unknown resistors (STANDARD 3 to UNKNOWN 3)

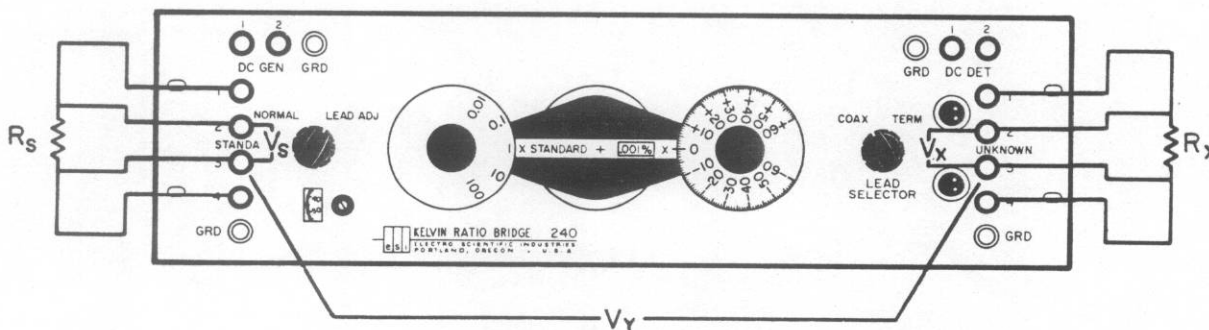

FIG. 3.6

It can be seen that the auxiliary ratio accuracy is relatively unimportant so long as the yoke voltage drop V_y is much smaller than the sum of the standard and unknown voltages $V_s + V_x$. When the yoke voltage is not negligible, it is important that the auxiliary ratio be accurately matched to the main ratio,

so that $(d_m - d_a) = 0$. The effect of any error or change in adjustment in the main ratio will be magnified by the factor $(1 + \frac{V_y}{V_s + V_x})$ if the auxiliary ratio is not adjusted to match the main ratio.

The voltage ratio $\frac{V_y}{V_s + V_x}$ can either be calculated from measured voltages (Fig. 3.6) or estimated from the resistance ratio $\frac{R_y}{R_s + R_x}$. Each ratio error is the difference between the errors or deviations of the two resistors from their nominal values, in % or ppm (this is an approximation accurate to 1 ppm for resistors of 0.1% accuracy).

The manufacturing tolerance for the main ratio (d_m) is ± 10 ppm on the 1 X STANDARD Multiplier and ± 50 ppm on all others. The tolerance for the matching of the auxiliary ratio to the main ratio ($d_m - d_a$) is ± 50 ppm for the 0.01 X, 0.1 X and 1 X, ± 500 ppm for the 10 X and ± 5000 ppm for the 100 X STANDARD Multiplier. These tolerances do not take into account errors introduced by lead resistances.

so that $(d_m - d_1) = 0$. The effect of any error or change in resistance is
 the main ratio will be magnified by the factor $(1 + \frac{V}{V_s + V})$ if the auxiliary
 ratio is not adjusted to match the main ratio.

The voltage ratio $\frac{V_x}{V_s + V_x}$ can either be calculated from measured voltages
 (Fig. 2.c) or estimated from the resistance ratio $\frac{R_x}{R_s + R_x}$. Error ratio error
 is the difference between the errors or deviations of the two resistors from
 their nominal values, in δ or ppm (this is an approximation accurate to 1
 ppm for resistors of 0.1% accuracy).

The manufacturing tolerance for the ratio ratio (d_m) is ± 10 ppm for the 1 X
 STANDARD Midgetter and ± 20 ppm for all others. The tolerance for the
 matching of the auxiliary ratio to the main ratio $(d_m - d_1)$ is ± 20 ppm for
 the 0.1 X, 0.1 X and 1 X, ± 50 ppm for the 10 X and ± 500 ppm for the
 100 X STANDARD Midgetter. These tolerances do not take into account
 errors introduced by lead resistances.

SECTION IV

CALIBRATION

4.1 INTRODUCTION

This section provides MODEL 240 KELVIN RATIO BRIDGE calibration procedures for those that have the necessary facilities. Calibration should be performed in a laboratory environment. If this is not possible return the instrument to the factory or an authorized service facility for calibration.

The 240 is carefully tested and calibrated prior to shipment to insure that it conforms to published specifications. However, calibration should be performed periodically, always after repair or replacement of parts, for certification of traceability or when measurement accuracy better than that stated in the specifications is desired.

4.1.1 EQUIPMENT REQUIRED

- 1) 100 kilohm per step transfer standard: A series string of ten resistors with terminals brought out at each junction. Each resistor should be within $\pm 0.005\%$ of its nominal value with a short term drift of less than ± 1 ppm. (ESI MODEL SR 1010 or equivalent).
- 2) Shorting bars: Paralleling straps for connecting ten resistors of the transfer standard in parallel and nine of the resistors in series-parallel. (ESI MODEL SB 103 or equivalent).
- 3) Decade resistor: 0 to 10 kilohms in 0.01 ohm steps, with an accuracy of $\pm(0.1\% + 0.01 \text{ ohm})$ or better, a short term stability of at least 1 ppm, and each decade should go from 0 to ten. (ESI MODEL DB 62 or equivalent).
- 4) Decade resistor: 0 to 100 ohms in 0.1 ohm steps, with an accuracy of $\pm(0.1\% + 0.01 \text{ ohm})$ or better, a short term stability of at least 1 ppm, and each decade should go from 0 to ten. (ESI MODEL DB 42 or equivalent).
- 5) Screwdriver: A small screwdriver for adjusting the test lead compensation rheostat.

4.2 INCREMENTAL ACCURACY

4.2.1 DEVIATION DIAL CALIBRATION

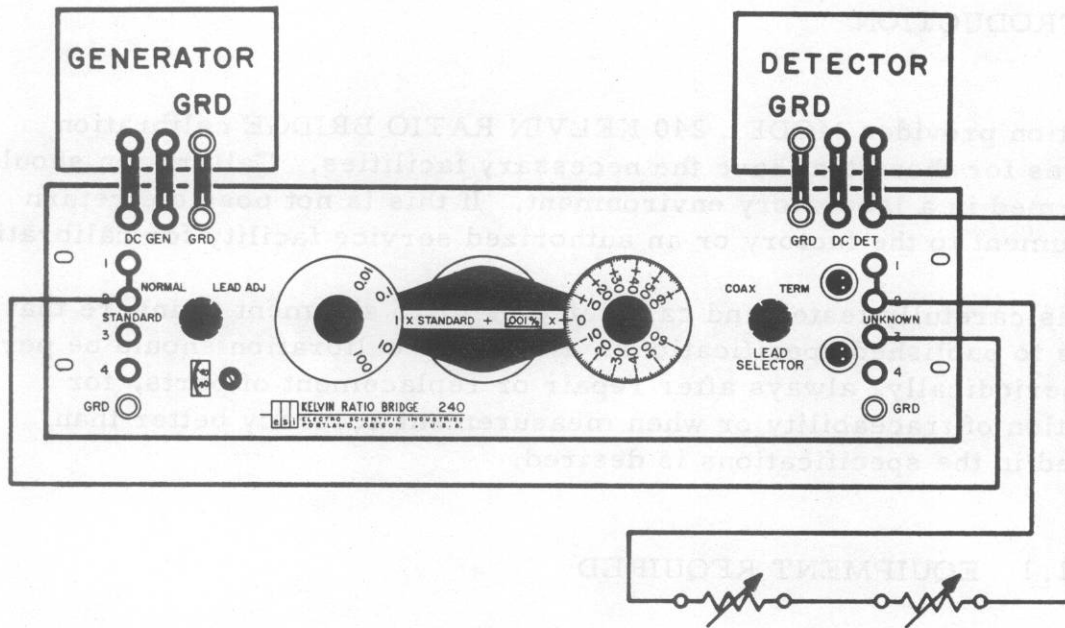

FIG. 4.2.1

- 1) Connect the generator and detector to the bridge. See Section 2.4.
- 2) Set the Deviation Multiplier to 1 ppm.
- 3) Set the Deviation dial to 0.
- 4) Set the Standard Multiplier to 1 X.
- 5) Set the LEAD SELECTOR to TERM.
- 6) Set the LEAD ADJ switch to NORMAL.
- 7) Connect bridge terminals UNKNOWN 3 and STANDARD 2 together. Be sure good contact is made to both ends of the connecting lead.

- 8) Connect the two decade resistance boxes in series and connect to terminals UNKNOWN 2 and DET 2 of the bridge. See Section 4.1.1 EQUIPMENT REQUIREMENTS for recommended decade resistance boxes.
- 9) Connect terminal STANDARD 1 to STANDARD 2 and UNKNOWN 1 to UNKNOWN 2. There should be no connections made to terminals STANDARD 3 or 4.
- 10) Set the 0.1 ohm per step decade resistor to 55.5 ohms and the 0.01 ohm per step decade resistor to approximately 9,944.50. This will allow the deviation dial to be checked to ± 50 divisions by changing only one decade of the 0.1 Ω per step box on each deviation range.
- 11) Turn the generator on and balance the bridge with the 0.01 ohm per step decade resistor leaving the 0.1 ohm per step decade resistor at 55.5 ohms. Be sure the generator is limited to a maximum of 1 watt.
- 12) Set the 0.1 ohm per step decade resistor to the values indicated in the table below. Balance the bridge with the Deviation dial at each indicated step. The Deviation dial should be within 1 dial division of the value indicated in the right hand column.

DEV MULT	DECADE RES Setting in ohms	DEV DIAL Setting in dial div
1 ppm X	55.0	-50 \pm 1
	55.1	-40 \pm 1
	55.2	-30 \pm 1
	55.3	-20 \pm 1
	55.4	-10 \pm 1
	55.5	0
	55.6	+10 \pm 1
	55.7	+20 \pm 1
	55.8	+30 \pm 1
	55.9	+40 \pm 1
	55. TEN	+50 \pm 1

DEV MULT	DECADE RES Setting in ohms	DEV DIAL Setting in dial div
0.001% X	50.5	-50±1
	51.5	-40±1
	52.5	-30±1
	53.5	-20±1
	54.5	-10±1
	55.5	0±1
	56.5	+10±1
	57.5	+20±1
	58.5	+30±1
	59.5	+40±1
	5 TEN.5	+50±1
0.01% X	05.5	-50±1
	15.5	-40±1
	25.5	-30±1
	35.5	-20±1
	45.5	-10±1
	55.5	0±1
	65.5	+10±1
	75.5	+20±1
	85.5	+30±1
	95.5	+40±1
	TEN 5.5	+50±1

DEV MULT	DECADE RES Setting in ohms	DEV DIAL Setting in dial div
0.001% X	50.5	-50±1
	51.5	-40±1
	52.5	-30±1
	53.5	-20±1
	54.5	-10±1
	55.5	0±1
	56.5	+10±1
	57.5	+20±1
	58.5	+30±1
	59.5	+40±1
	5 TEN.5	+50±1
0.01% X	05.5	-50±1
	15.5	-40±1
	25.5	-30±1
	35.5	-20±1
	45.5	-10±1
	55.5	0±1
	65.5	+10±1
	75.5	+20±1
	85.5	+30±1
	95.5	+40±1
	TEN 5.5	+50±1

4.2.2 LEAD COMPENSATION ADJUSTMENT DIAL CALIBRATION

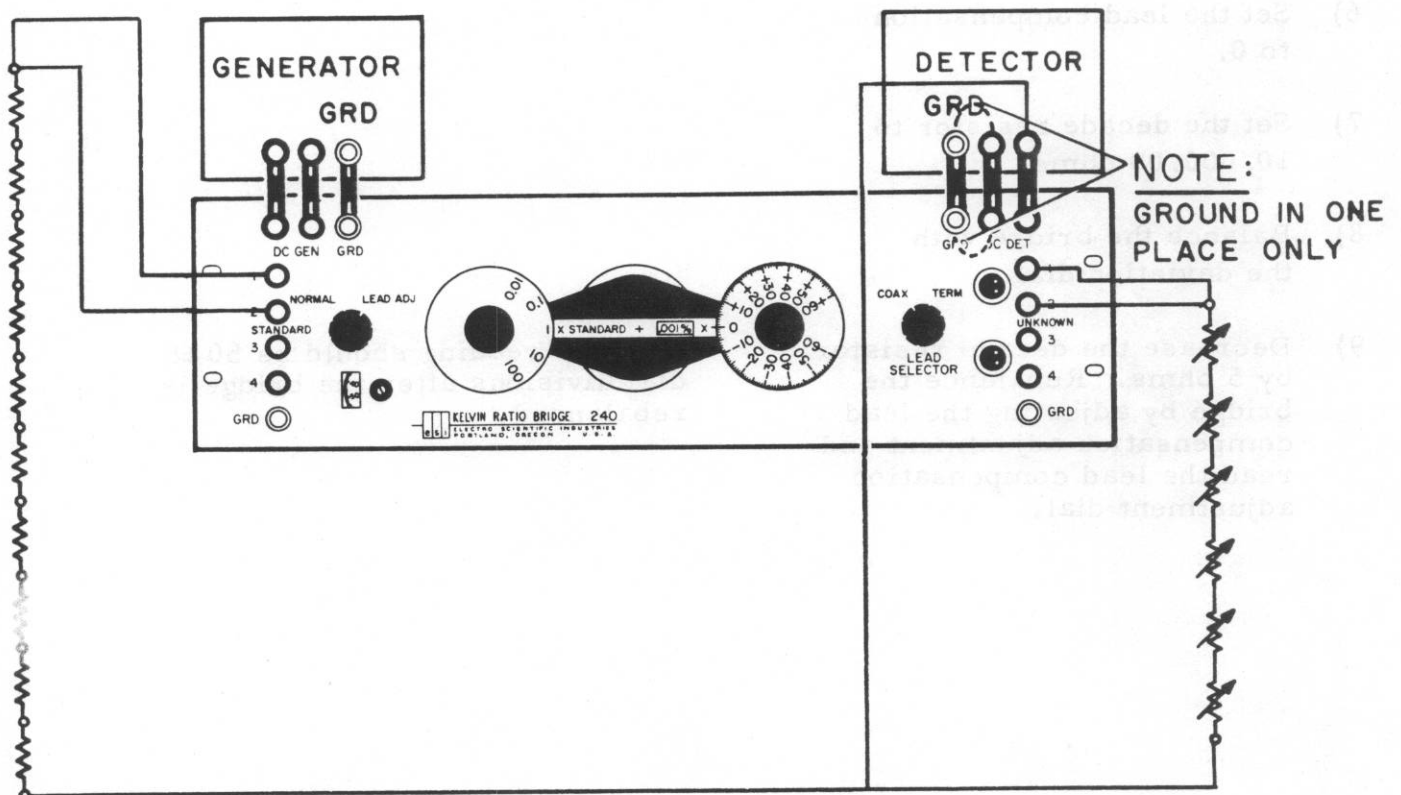

FIG. 4.2.2

- 1) Connect the 0.01 ohm per step decade resistor and the series-connected 100K per step resistance transfer standard as shown in Fig. 4.2.2.
 - 2) Set the Standard Multiplier to 0.01 X.
 - 3) Set the Deviation Multiplier to 0.001% X.
 - 4) Set the LEAD SELECTOR to TERM.
- Use a lead with less than 20 milliohms on UNKNOWN terminal 2.

5) Set the LEAD ADJ switch to NORMAL.

6) Set the lead compensation to 0.

7) Set the decade resistor to 10,000.00 ohms.

8) Balance the bridge with the deviation dial.

9) Decrease the decade resistor by 5 ohms. Rebalance the bridge by adjusting the lead compensation adjustment and read the lead compensation adjustment dial.

The dial reading should be 50 ± 5 dial divisions after the bridge is rebalanced.

4.3 MAIN RATIO CALIBRATION

4.3.1 1 X STANDARD MULTIPLIER RANGE

- 1) Connect the generator and detector to the bridge. See Section 2.4 GENERATOR-DETECTOR CONNECTIONS.
- 2) Set the Deviation Multiplier to 1 ppm X.
- 3) Set the Deviation dial to 0.
- 4) Set the Standard Multiplier to 1 X.
- 5) Set the LEAD SELECTOR to TERM.
- 6) Set the LEAD ADJ switch to LEAD ADJ.
- 7) Connect test leads from UNKNOWN 1 and 2 to UNKNOWN 3 and balance the bridge with the Lead Compensation adjustment.
- 8) Change the LEAD ADJ switch to NORMAL.
- 9) Connect ten resistors of the 100K per step transfer standard (item 1 of Section 4.1.1) in parallel, and connect this parallel combination together with the 0.01 ohm per step decade resistor (item 3 of Section 4.1.1) to the bridge as shown in Fig. 4.3.1. The resistance of the lead to STANDARD 2 should be kept less than 10 milliohms.

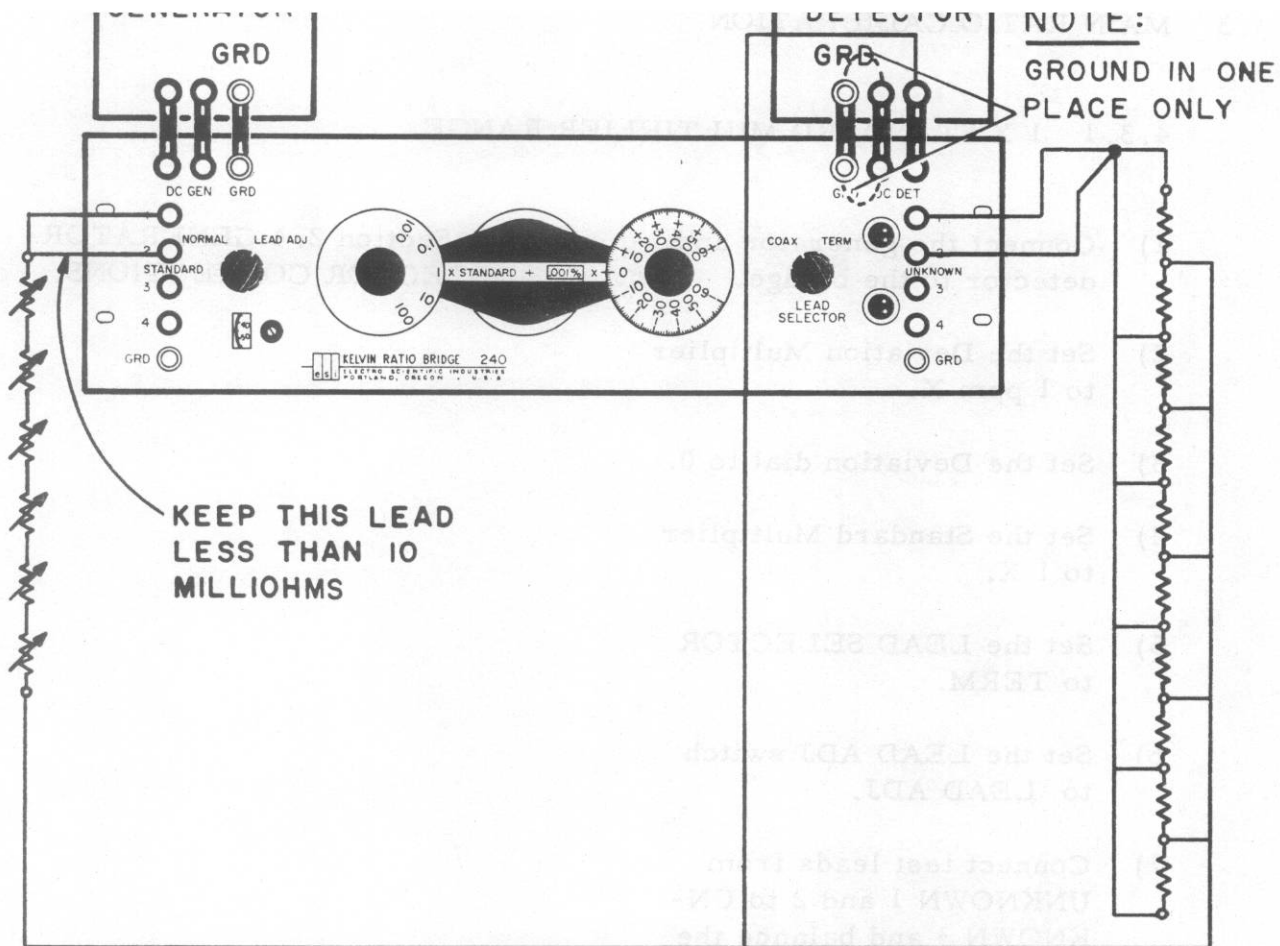

FIG. 4.3.1

- 10) Balance the bridge with the decade resistor.
- 11) Interchange the UNKNOWN 1 and 2 leads with the STANDARD 1 and 2 leads at the decade resistor and the transfer standard.
- 12) Rebalance the bridge with the Deviation dial.

It should balance with a resistance setting of about 10 kilohms on the decade resistor.

The transfer standard is now the standard and the decade resistor the unknown.

13) Set the Deviation dial at one-half the reading obtained in step 12.

This deviation setting is the bridge error for the 1 X STANDARD and 1 ppm X deviation multiplier ranges; it should not exceed 10 dial divisions (10 ppm).

14) Rebalance the bridge using the decade resistor.

This adjustment makes the decade resistor exactly equal to the resistance of the parallel combination.

15) For better adjustment accuracy, set the deviation dial to 0 and rebalance the bridge by adjusting R_{11} .

See Fig. 5.3.1 for location of R_{11} .

16) Change the Deviation Multiplier to 0.001% X and rebalance the bridge with the Deviation dial.

This deviation reading is the bridge error for the 1 X STANDARD and 0.001% X deviation multiplier ranges; it should not exceed 1 dial division (0.001%).

17) For better adjustment accuracy, set the deviation dial at 0 and rebalance the bridge by adjusting R_8 .

See Fig. 5.3.1 for location of R_8 .

18) Change the Deviation Multiplier to 0.01% X and rebalance the bridge with the Deviation dial.

This deviation reading is the bridge error for the 1 X STANDARD and 0.01% X deviation multiplier ranges; it should not exceed 1 dial division (0.01%).

4.3.2 100 X AND 0.01 X STANDARD MULTIPLIER RANGES

1) Set the Standard Multiplier to 100 X and the deviation multiplier to 1 ppm X.

All other dial settings including those of the decade resistor remain as in Section 4.3.1.

2) Remove the paralleling connection from the transfer standard and connect its ten resistors in series to the bridge as shown in Fig. 4.3.2.

The series connection of the transfer standard makes its resistance exactly 100 times that of the decade resistor.

Deviation dial.

the error of the 100 X multiplier; it should be less than 50 ppm.

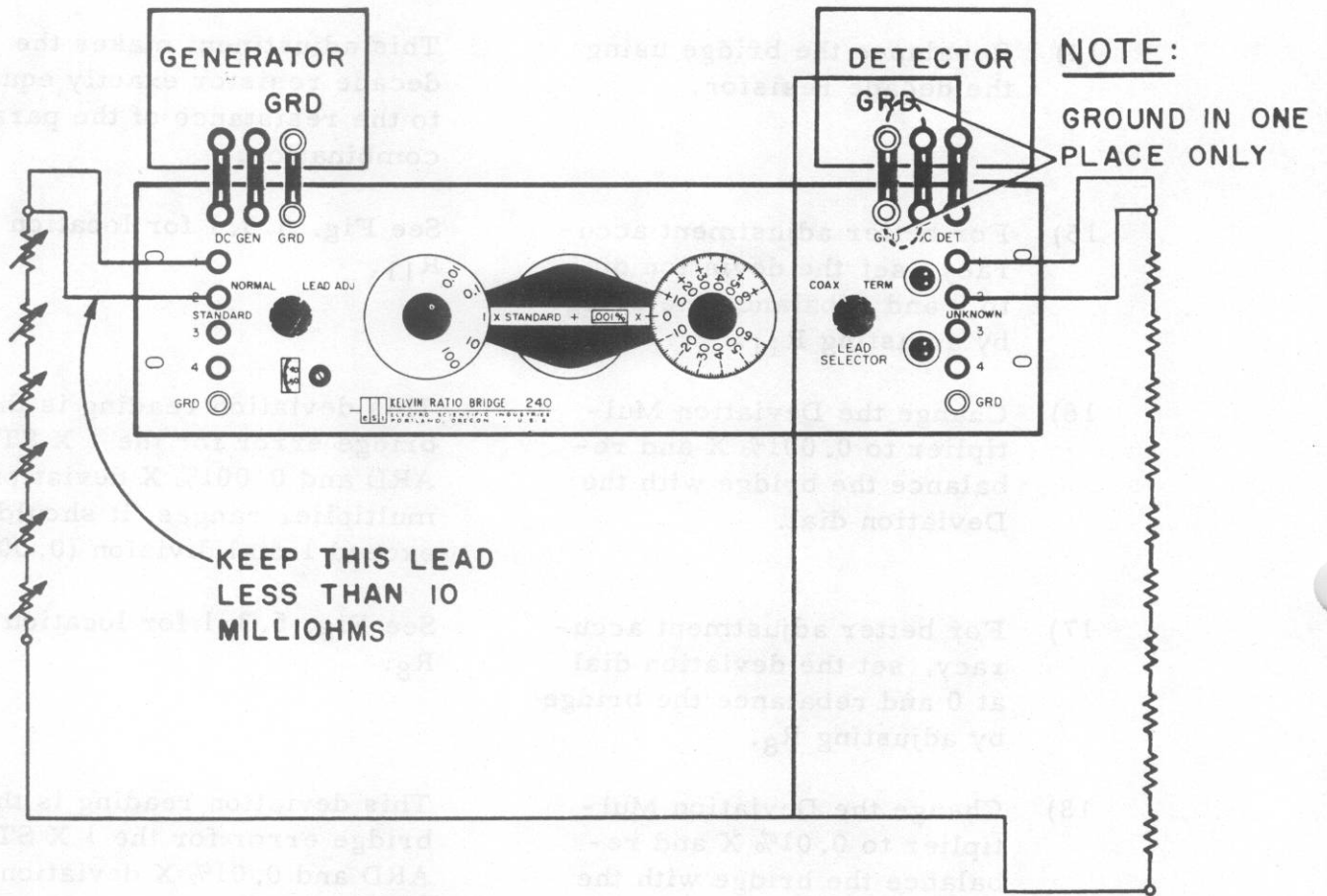

FIG. 4.3.2

- 4) Change the Standard Multiplier setting to 0.01 X.
- 5) Interchange connections to transfer standard and decade resistor; do not interchange leads.
- 6) Balance the bridge with the Deviation dial.

The transfer standard is now the standard and the decade resistor the unknown.

This Deviation dial reading is the error of the 0.01 X multiplier and should be less than ± 50 ppm.

4.3.3 10 X AND 0.1 X STANDARD MULTIPLIER RANGES

- 1) Set the Standard Multiplier at 10 X.
- 2) Connect the first nine resistors of the transfer standard in series-parallel.
- 3) Connect the tenth resistor (the one not included in the series-parallel combination) and the decade resistor to the bridge as shown by the solid lines in Fig. 4.3.3.

All other dial settings including those of the decade resistor remain as in Section 4.3.2.

The series-parallel combination will have approximately 10 times the resistance of the decade resistor, and approximately the same value as any individual resistor in the transfer standard.

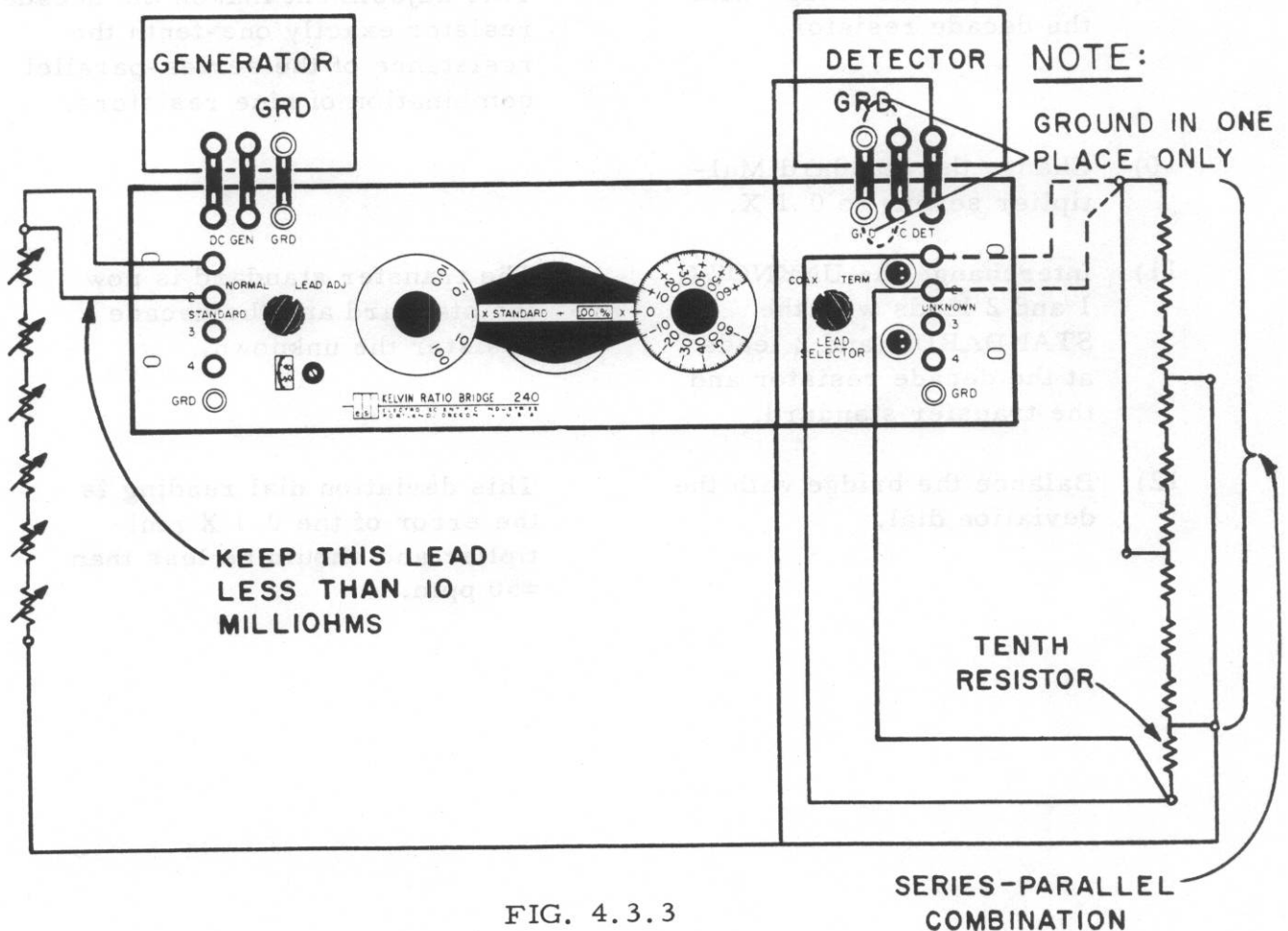

FIG. 4.3.3

- 4) Balance the bridge with the deviation dial. Call this reading D_1 .
- 5) Transfer the UNKNOWN 1 and 2 leads to the dotted connection shown in Fig. 4.4.3 to measure the series-parallel combination of nine resistors.
- 6) Balance the bridge with the deviation dial. Call this reading D_2 .
- 7) Calculate $D_3 = 0.1D_1 + 0.9D_2$. D_3 is the error of the 10 X multiplier and should be less than ± 50 ppm.
- 8) Set the deviation dial to D_3 . This adjustment makes the bridge ratio exactly 10:1.
- 9) Rebalance the bridge with the decade resistor. This adjustment makes the decade resistor exactly one-tenth the resistance of the series-parallel combination of nine resistors.
- 10) Change the Standard Multiplier setting to 0.1 X.
- 11) Interchange the UNKNOWN 1 and 2 leads with the STANDARD 1 and 2 leads at the decade resistor and the transfer standard. The transfer standard is now the standard and the decade resistor the unknown.
- 12) Balance the bridge with the deviation dial. This deviation dial reading is the error of the 0.1 X multiplier and should be less than ± 50 ppm.

4.4 AUXILIARY RATIO CALIBRATION

4.4.1 RATIO MATCHING

The following tests check the accuracy with which the auxiliary ratio (between STANDARD 3 and UNKNOWN 3) is matched to the main ratio (between STANDARD 2 and UNKNOWN 2). The circuit of Fig. 4.4.1 is used to check the ratio matching accuracy on all Standrad Multiplier ranges, Deviation Multiplier ranges, Deviation dial settings and Lead Compensation adjustment settings.

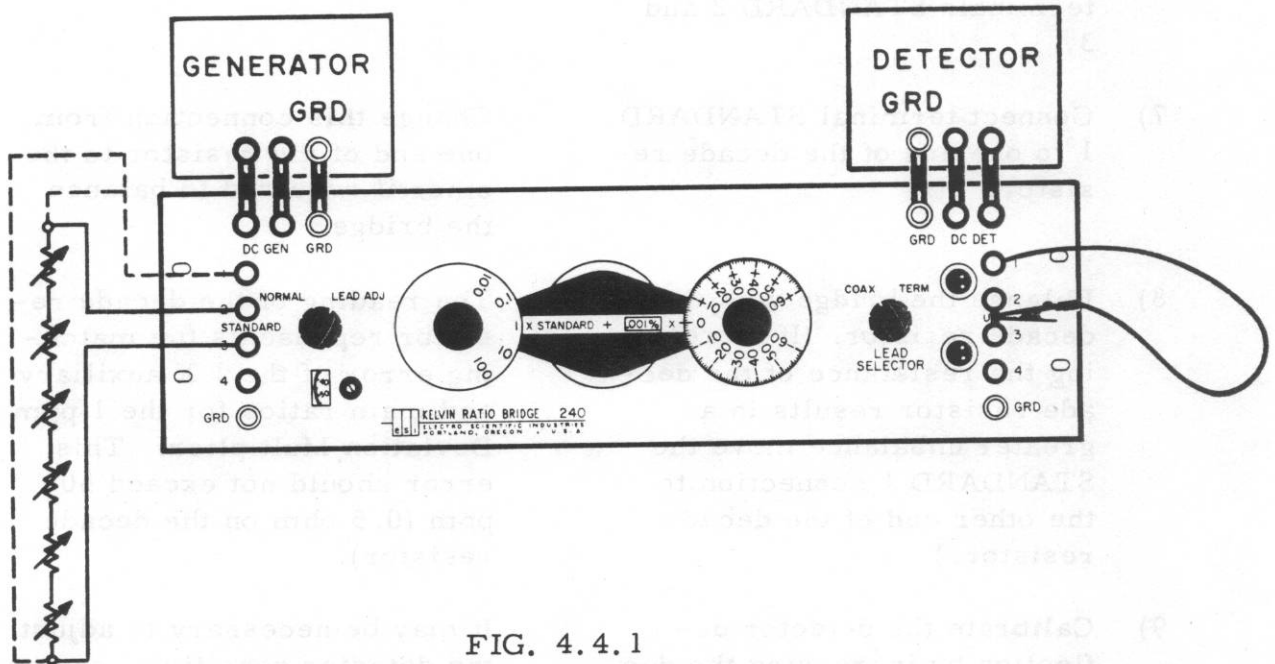

FIG. 4.4.1

- 1) Set the Standard Multiplier to 1 X and the Deviation Multiplier to 1 ppm X.
- 2) Set the Deviation dial and the Lead Compensation adjustment dial to 0.

- 3) Set the LEAD ADJ switch to NORMAL.
- 4) Connect terminals UN-KNOWN 2 and 3 together.
- 5) Connect UNKNOWN 1 to the center of the connecting link between UNKNOWN 2 and 3.
- 6) Connect the 0.01 ohm per step decade resistor, with all dials set to 0, between terminals STANDARD 2 and 3.
- 7) Connect terminal STANDARD 1 to one end of the decade resistor.
- 8) Balance the bridge with the decade resistor. (If increasing the resistance of the decade resistor results in a greater unbalance move the STANDARD 1 connection to the other end of the decade resistor.)
- 9) Calibrate the detector deflection by increasing the decade resistor by 0.01 ohm (1 ppm change) and noting the resulting detector deflection.
- 10) Return the decade resistor to the balance point and slowly vary the Deviation dial from +60 to -60 noting the deflection of the detector.

Change this connection from one end of the resistor to the other if required to balance the bridge.

The reading of the decade resistor represents the matching error of the 1 X auxiliary and main ratios for the 1 ppm Deviation Multiplier. This error should not exceed 50 ppm (0.5 ohm on the decade resistor).

It may be necessary to adjust the detector sensitivity or generator voltage to obtain a practical deflection; one that is about three fourths full scale.

This checks the tracking of the auxiliary and main ratio deviation rheostats on the 1 ppm range. the detector should not deflect by more than the amount noted in step 9 above.

11) Change the Deviation Multiplier to 0.001% X and set the Deviation dial to 0.

12) Balance the bridge with the decade resistor.

13) Slowly vary the Deviation dial from +60 to -60 noting the detector deflection.

14) Change the Deviation Multiplier to 0.01% X and set the Deviation dial to 0.

15) Balance the bridge with the decade resistor.

16) Slowly vary the Deviation dial from +60 to -60 noting the detector deflection.

17) Change the Deviation Multiplier to 1 ppm X and set the Deviation dial to 0.

18) Change the Standard Multiplier to 0.1 X and balance the bridge with the decade resistor.

The reading of the decade resistor represents the matching error of the 1 X auxiliary and main ratios for the 0.001% Deviation Multiplier. This error should not exceed 50 ppm (0.5 ohm on the decade resistor).

The maximum detector deflection should be no greater than that produced by a 0.1 ohm change in the decade resistor (a 0.001% change).

The reading of the decade resistor represents the matching error of the 1 X auxiliary and main ratios for the 0.001% Deviation Multiplier. This error should not exceed 50 ppm (0.5 ohm on the decade resistor).

The maximum detector deflection should be no greater than that produced by a 1 ohm change in the decade resistor (a 0.01% change).

The reading of the decade resistor represents the matching error of the 0.1 X auxiliary and main ratios for the 1 ppm Deviation Multiplier. This error should not exceed 50 ppm (0.5 ohm on the decade resistor).

Change the Standard Multiplier to 0.01 X and balance the bridge with the decade resistor.

20) Check the tracking of the lead compensation rheostats by slowly varying the Lead Compensation adjustment from 0 to maximum noting the detector deflection.

21) Reset the Lead Compensation adjustment to 0, change the LEAD ADJ switch to LEAD ADJ, and note the detector deflection.

22) Return the LEAD ADJ switch to NORMAL.

23) Change the Standard Multiplier to 10 X and balance the bridge with the decade resistor.

24) Change the Standard Multiplier to 100 X and balance the bridge with the decade resistor.

The reading of the decade resistor represents the matching error of the 0.01 X auxiliary and main ratios for the 1 ppm Deviation Multiplier. This error should not exceed 50 ppm (0.5 ohm on the decade resistor).

The maximum detector deflection should be no greater than that produced by a 0.2 ohm change in the decade resistor (a 2 milliohm change in the lead compensation rheostat).

This checks the matching of the lead adj circuit to the normal circuit. The maximum detector deflection should not be greater than that produced by a 0.1 ohm change in the decade resistor (a 1 milliohm change in the lead compensation).

The reading of the decade resistor represents the matching of the 10 X auxiliary and main ratios for the 1 ppm Deviation Multiplier. This error should not exceed 500 ppm (5 ohms on the decade resistor).

The reading of the decade resistor represents the matching of the 100 X auxiliary and main ratios for the 1 ppm X Deviation Multiplier. This error should not exceed 5000 ppm (50 ohms on the decade resistor).

4.5 YOKE RESISTANCE

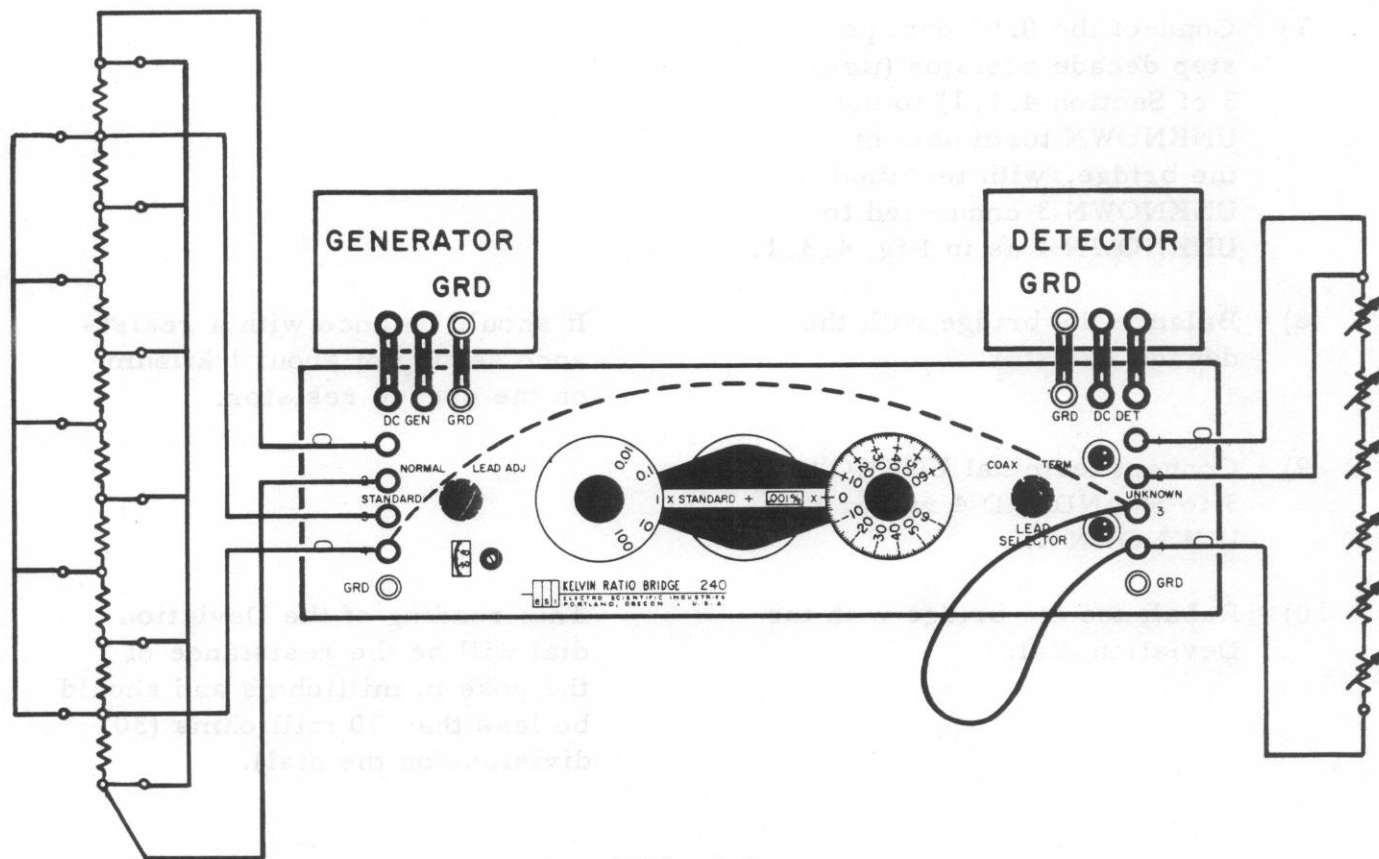
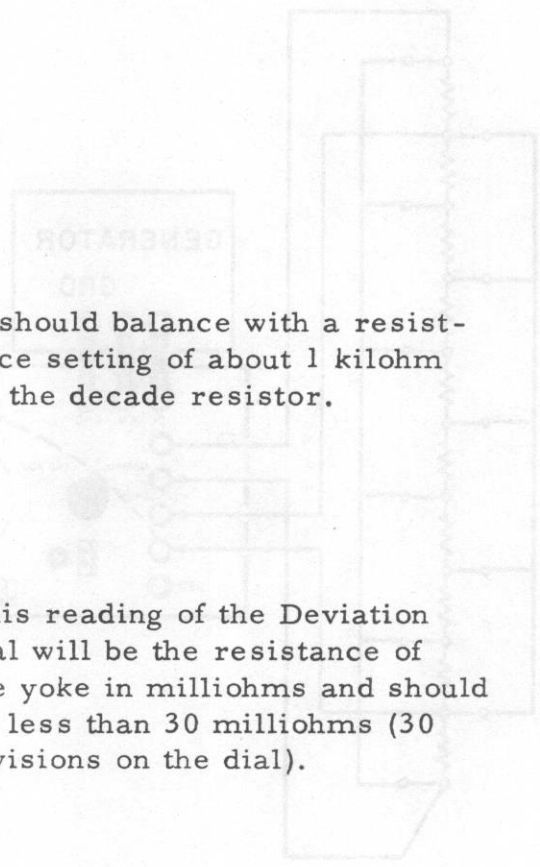

FIG. 4.5

- 1) Set the Standard Multiplier to 0.1 X.
- 2) Set the Deviation Multiplier to 1 ppm X.
- 3) Set the Deviation dial to 0.
- 4) Set the LEAD ADJ switch to NORMAL.
- 5) Set the LEAD SELECTOR to TERM.

- 6) Connect 10 resistors to the transfer standard in parallel and connect to the STANDARD terminals of the bridge.
- 7) Connect the 0.01 ohm per step decade resistor (item 3 of Section 4.1.1) to the UNKNOWN terminals of the bridge, with terminal UNKNOWN 3 connected to UNKNOWN 4 as in Fig. 4.3.1.



- 8) Balance the bridge with the decade resistor.
- 9) Connect terminal UNKNOWN 3 to STANDARD 4 rather than UNKNOWN 4.
- 10) Rebalance the bridge with the Deviation dial.

It should balance with a resistance setting of about 1 kilohm on the decade resistor.

This reading of the Deviation dial will be the resistance of the yoke in milliohms and should be less than 30 milliohms (30 divisions on the dial).

SECTION V

MAINTENANCE

5.1 PREVENTIVE MAINTENANCE

The following procedures should be performed periodically to insure maximum accuracy and reliability from the ESI MODEL 240 KELVIN RATIO BRIDGE.

If the need for major repairs is apparent, it is recommended that the instrument be returned to the factory for service and repair. Our Service Department will be glad to furnish necessary repair information as well as any replacement parts. Unauthorized repairs will invalidate our warranty. If the instrument is more than one year old when returned to the factory a reasonable charge may be expected for replacement parts or for complete reconditioning.

5.1.1 VISUAL INSPECTION

First inspect the bridge externally for dial orientation, damaged binding posts and caps, and dirt around the binding post insulators. Next remove the dust cover as described in Section 5.1.2 and inspect the unit for possible internal defects. These defects include such things as loose or broken connections, damaged switch contacts, worn potentiometers and sliders, and heat-damaged resistors.

5.1.2 REMOVING THE DUST COVER

Prepare a clean, smooth area to set the instrument. Be sure that no projections or pointed objects will be underneath the bridge panel. See that there are no metal filings in the area.

Remove the instrument from the rack and place it face down on the prepared surface.

Loosen the fasteners on the back of the instrument, then carefully slide the dust cover off.

5.1.3 CLEANING AND LUBRICATION

Clean the front panel with a soft, dry, lint free cloth being particularly careful to remove all dirt from around the binding post insulators. The only internal components which require cleaning and lubrication are the deviation rheostats and occasionally the switch decks.

Clean and lubricate the deviation rheostats as follows:

Caution: Do not use solvents on the rheostats. Solvents may leave a residue which can affect their performance.

- a) Polish the contact surfaces lightly with abrasive cloth (Crocus cloth or equivalent).
- b) Remove loose particles by wiping with a Nylon cloth.
- c) Apply a moderate amount of pure petroleum jelly to the contact surface.

The switch decks are carefully lubricated at the time of manufacture and are protected from contamination by the dust cover. They should rarely, if ever, need maintenance. It is recommended that they be cleaned and lubricated only if it is determined that they are not making good electrical contact. If it is determined that the switch decks are in need of cleaning proceed as follows:

- a) Apply solvent (Freon printed circuit solvent or equivalent) to the contact surfaces with a small brush or pipe cleaner.
- b) Wipe surface with clean dry brush or dry with low pressure air.
- c) Apply a thin coating of lubricant (Oak #2008 or equivalent) to the contact surface.
- d) Apply two drops of the same oil to each of the switch bearings and detent mechanisms.
- e) Remove the excess oil with a clean dry cloth and remove all traces of lint with a soft brush.

5.1.4 CHECKING THE DIAL SETTINGS

In order to check that the dials are in their proper positions with respect to the shafts, the following procedure can be used:

Turn the STANDARD MULTIPLIER DIAL clockwise until a stopped position is reached. The dial should then read 0.01X.

Turn the DEVIATION MULTIPLIER DIAL clockwise until a stopped position is reached. The dial should then read 0.01%X.

Turn the DEVIATION DIAL clockwise until the end point is felt. The dial should read -60. Turn the dial counter clockwise until the end point is felt. The dial should read +60.

5.1.5 REPLACING THE DUST COVER

Be sure that the interior of the dust cover is completely clear of all foreign material.

Slip the dust cover over the bridge being careful not to touch the dust cover against the bridge resistors. Replace the dust cover screws.

Replace the assembled instrument in the rack.

The following table lists various abnormal indications, probable cause and corrective procedures for the MODEL 240 KELVIN RATIO BRIDGE. Troubles may be located quickly by first performing a basic measurement (Section II) to aid in locating the trouble, then refer to the following table and component location illustrations. Calibrate the instrument after any repair or replacement is performed. (See Section IV, CALIBRATION for recommended procedures.)

5.2.1 TROUBLE SHOOTING CHART

SYMPTOM	PROBABLE CAUSE	PROCEDURE
Deviation dial setting affects balances on Lead Compensation.	Deviation potentiometers not aligned properly.	Turn the deviation dial counter clockwise to the +60 position. Check that the arms of both potentiometers are then hitting their stops.
Adjusting the deviation dial causes erratic detector readings.	Dirty deviation potentiometers.	Polish the contact surface lightly with Crocus cloth, remove the loose particles by wiping with a Nylon cloth and then lubricate liberally with pure petroleum jelly.
No detector deflection, apparent loss of generator voltage.	Bad connection to the terminal STANDARD 1 or UNKNOWN 1.	Check all contacts to be sure they are tight and contact surfaces are clean. Check all leads for continuity.
Detector indicates extreme bridge unbalance.	Bad connection to the STANDARD or UNKNOWN terminals.	Check all contacts to be sure they are tight and contact surfaces are clean. Check all leads for continuity.

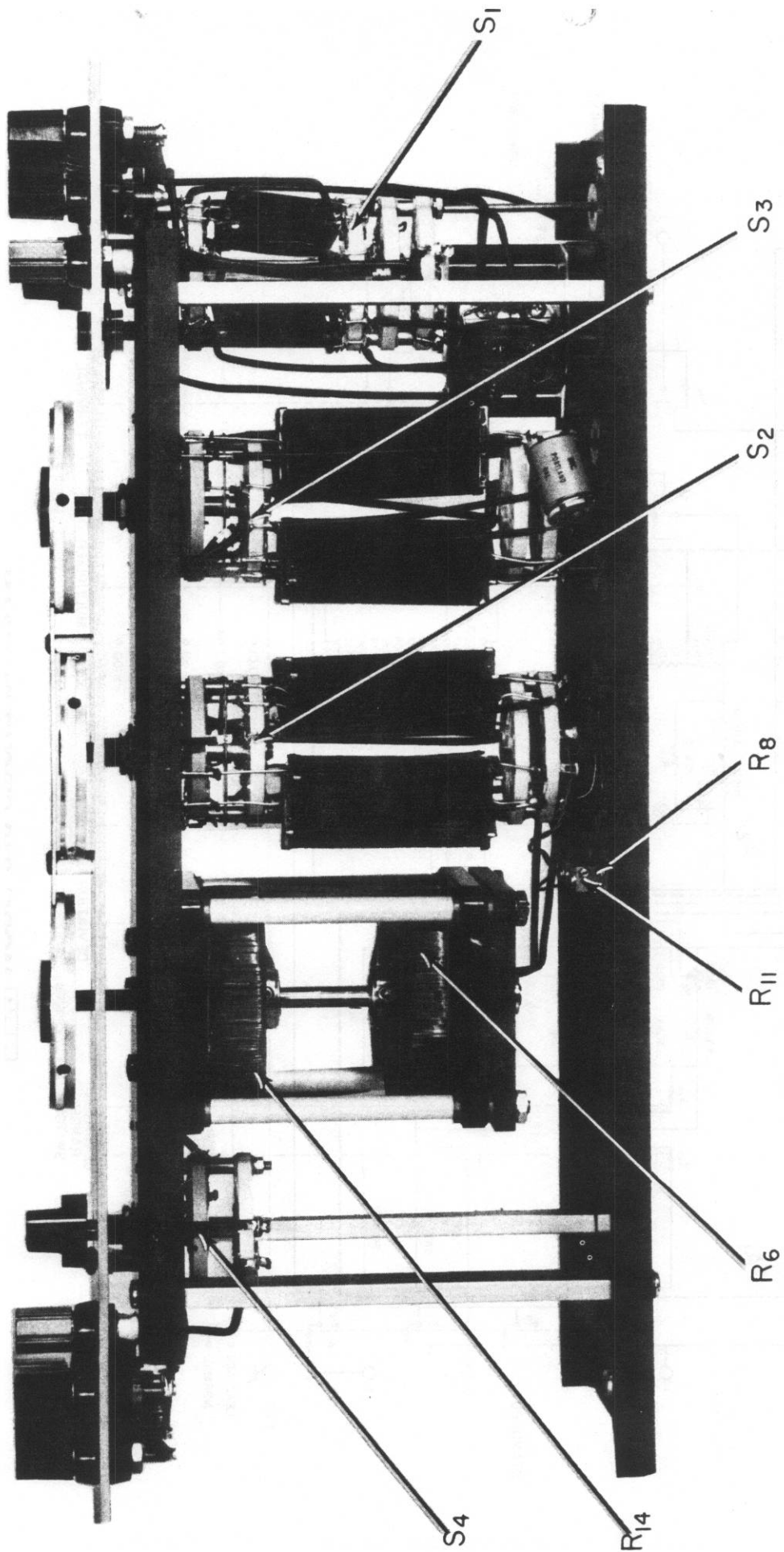
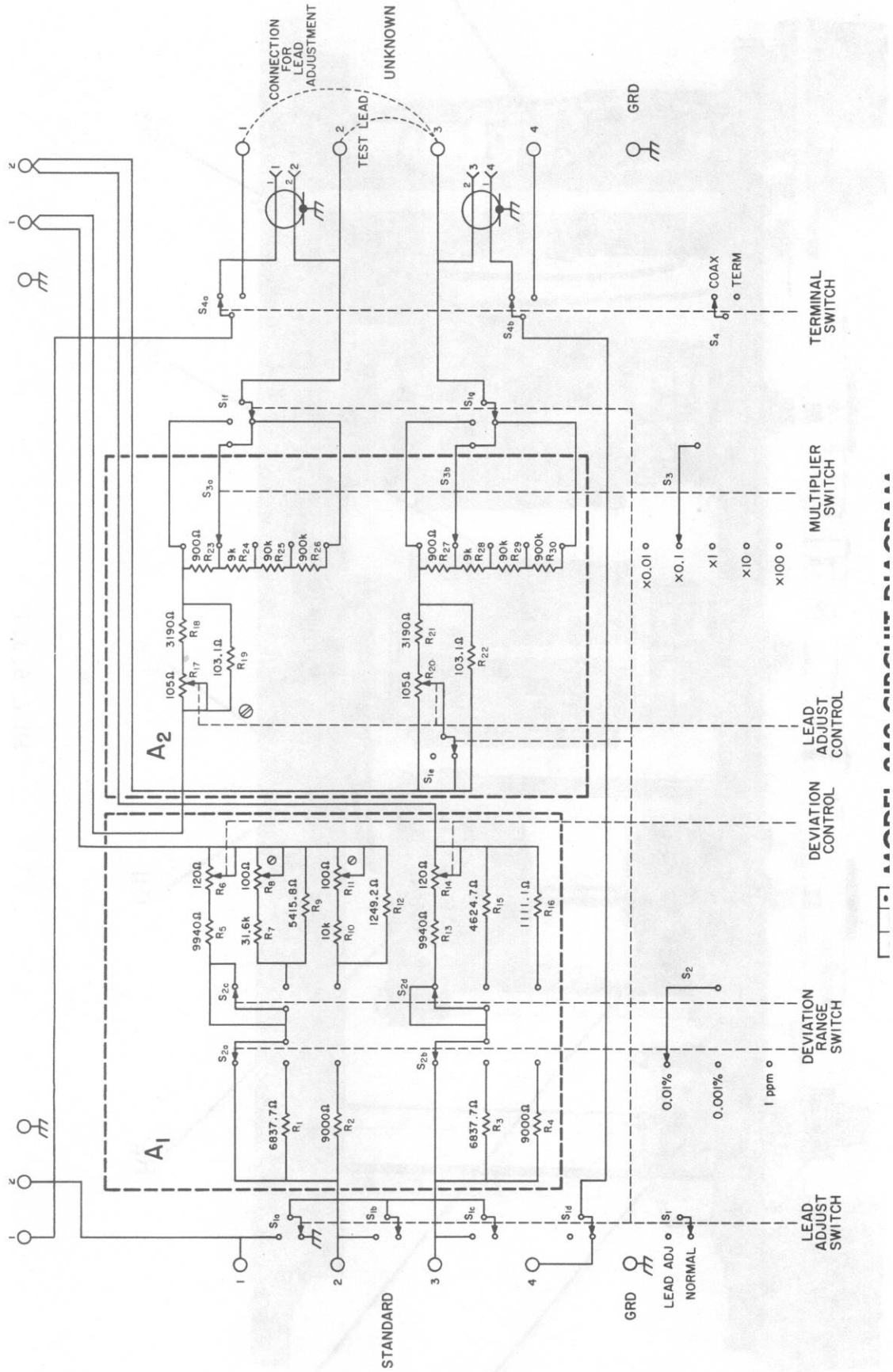

FIG. 5.3.1



5.4 PARTS LIST

The following parts list is in alpha numerical order of the circuit reference designator. Miscellaneous parts are included at the end of the list. Manufacturer of the part is given in a code number according to the Federal Supply Code for Manufacturers; see list of manufacturers below. Parts recommended as spares to sustain operation in isolated locations are indicated in the recommended spare parts column.

Parts manufactured by Electro Scientific Industries must be ordered from the factory. When ordering parts from the factory include the following information:

Model and serial number of the instrument
 Electro Scientific Industries part number
 Circuit reference designator
 Description of part

CODE LIST OF MANUFACTURERS

11837	ELECTRO SCIENTIFIC INDUSTRIES Portland, Oregon
80294	BOURNS LABORATORIES, INC. Riverside, California

Ckt Ref	Description	Mfr.	ESI Part No.	Qty Used	Recm SP
A ₁	Ass'y, Deviation Range	11837	9536	1	1
A ₂	Ass'y, Multiplier	11837	9537	1	1
R ₁	Resistor, Fixed, Precision, 6837.7Ω, Part of Ass'y A ₁	11837	*	1	*
R ₂	Resistor, Fixed, Precision, 9K, Part of Ass'y A ₁	11837	*	1	*
R ₃	Resistor, Fixed, Precision, 6837.7Ω, Part of Ass'y A ₁	11837	*	1	*

* Replace entire Ass'y

ESI MODEL 240

Ckt Ref	Description	Mfr.	ESI Part No.	Qty Used	Recm SP
R ₄	Resistor, Fixed, Precision, 9K, Part of Ass'y A ₁	11837	*	1	*
R ₅	Resistor, Fixed, Precision, 9940Ω, Part of Ass'y A ₁	11837	*	1	*
R ₆	Resistor, Variable, 120Ω, Part of Ass'y A ₁	11837	*	1	*
R ₇	Resistor, Fixed, Precision, 31.6K, Part of Ass'y A ₁	11837	*	1	*
R ₈	Resistor, Variable, wire wound, 100Ω, Mfg. PN Trimpot 224L-1-101, Part of Ass'y A ₁	80294	8464	1	*
R ₉	Resistor, Fixed, Precision, 5115.8Ω, Part of Ass'y A ₁	11837	*	1	*
R ₁₀	Resistor, Fixed, Precision, 10K, Part of Ass'y A ₁	11837	*	1	*
R ₁₁	Resistor, Variable, wire wound, 100Ω, Mfg. PN Trimpot 224L-1-101, Part of Ass'y A ₁	80294	8464	1	*
R ₁₂	Resistor, Fixed, Precision, 1249.2Ω, Part of Ass'y A ₁	11837	*	1	*
R ₁₃	Resistor, Fixed, Precision, 9940Ω, Part of Ass'y A ₁	11837	*	1	*

* Replace entire Ass'y

Parts List
ESI MODEL 240

Ckt Ref	Description	Mfr.	ESI Part No.	Qty Used	Recm SP
R ₁₄	Resistor, Variable, 120Ω, Part of Ass'y A ₁	11837	*	1	*
R ₁₅	Resistor, Fixed, Precision, 4624.7Ω, Part of Ass'y A ₁	11837	*	1	*
R ₁₆	Resistor, Fixed, Precision, 1111.1Ω, Part of Ass'y A ₁	11837	*	1	*
R ₁₇	Resistor, Variable, 105Ω, Part of Ass'y A ₂	11837	*	1	*
R ₁₈	Resistor, Fixed, Precision, 3190Ω, Part of Ass'y A ₂	11837	*	1	*
R ₁₉	Resistor, Fixed, Precision, 103.1Ω, Part of Ass'y A ₂	11837	*	1	*
R ₂₀	Resistor, Variable, 105Ω, Part of Ass'y A ₂	11837	*	1	*
R ₂₁	Resistor, Fixed, Precision, 3190Ω, Part of Ass'y A ₂	11837	*	1	*
R ₂₂	Resistor, Fixed, Precision, 103.1Ω, Part of Ass'y A ₂	11837	*	1	*
R ₂₃	Resistor, Fixed, Precision, 900Ω, Part of Ass'y A ₂	11837	*	1	*
R ₂₄	Resistor, Fixed, Precision, 9K, Part of Ass'y A ₂	11837	*	1	*

* Replace entire Ass'y

ESI MODEL 240

Ckt Ref	Description	Mfr.	ESI Part No.	Qty Used	Recm SP
R ₂₅	Resistor, Fixed, Precision, 90K, Part of Ass'y A ₂	11837	*	1	*
R ₂₆	Resistor, Fixed, Precision, 900K, Part of Ass'y A ₂	11837	*	1	*
R ₂₇	Resistor, Fixed, Precision, 900Ω, Part of Ass'y A ₂	11837	*	1	*
R ₂₈	Resistor, Fixed, Precision, 9K, Part of Ass'y A ₂	11837	*	1	*
R ₂₉	Resistor, Fixed, Precision, 90K, Part of Ass'y A ₂	11837	*	1	*
R ₃₀	Resistor, Fixed, Precision, 900K, Part of Ass'y A ₂	11837	*	1	*
S ₁	Switch, Rotary, Lead Adjust	11837	8342	1	1
S ₂	Switch, Rotary, Range, Deviation, Part of Ass'y A ₁	11837	*	1	*
S ₃	Switch, Rotary, Multiplier, Part of Ass'y A ₂	11837	*	1	*
S ₄	Switch, Rotary, Lead Selector	11837	8323	1	1

* Replace entire Ass'y

MODEL RS 925A

RESISTANCE STANDARD

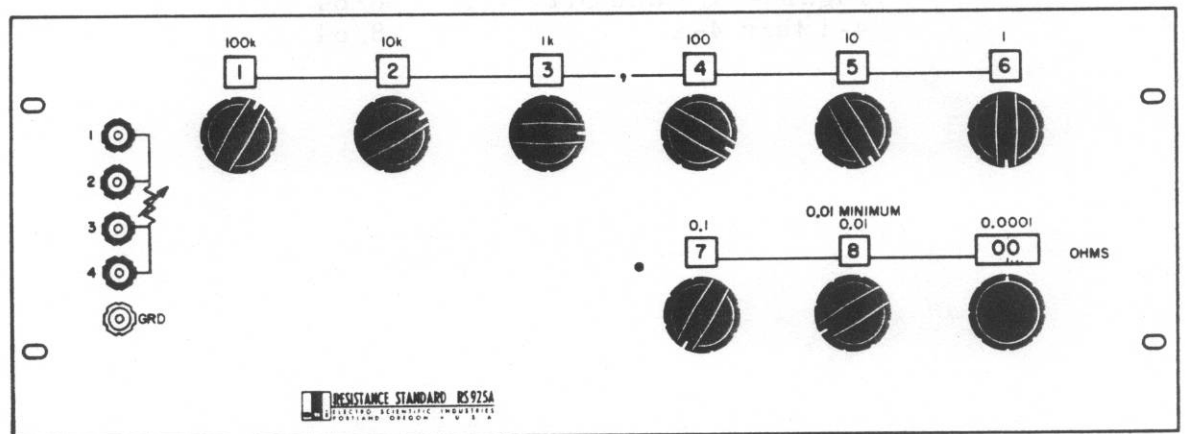

SERIAL NUMBER: _____
PART NUMBER: 8402

The following table lists the most recent revision of each page at the present printing:

<u>PAGES</u>	<u>DATE</u>
Title	1/70
A	1/70
i and ii	1/70
1-1	8/64
Panel Controls Figure	8/64
2-1 thru 2-3	8/64
3-1 and 3-2	8/64
Figures 3.1 and 3.2	8/64
4-1 thru 4-4	8/64

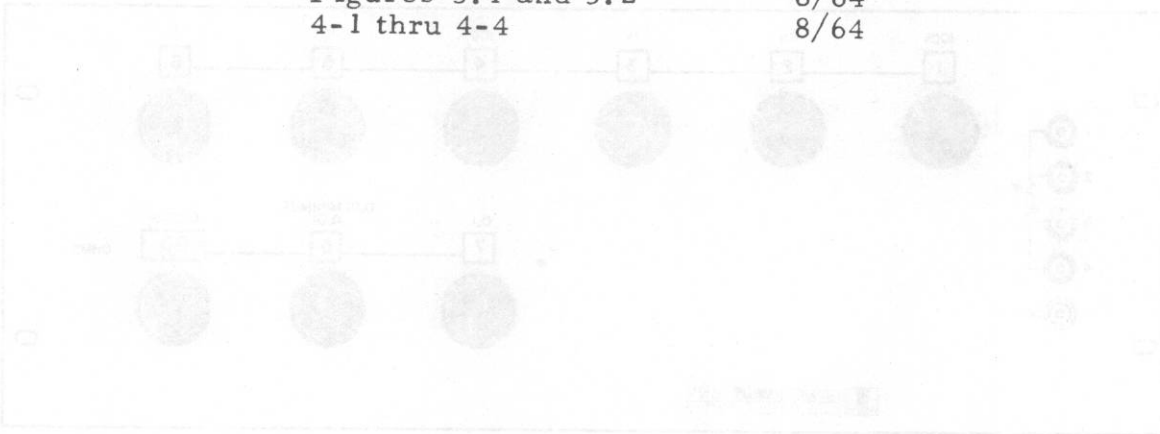

TABLE OF CONTENTS

I.	DESCRIPTION AND SPECIFICATIONS	
1.1	DESCRIPTION	1-1
1.2	SPECIFICATIONS	1-1
II.	OPERATING INSTRUCTIONS	
2.1	RESISTANCE SELECTION KNOBS	2-1
2.2	RESISTANCE TERMINALS	2-1
2.3	FOUR-TERMINAL APPLICATIONS	2-1
2.4	POWER LIMITATIONS	2-3
III.	PREVENTIVE MAINTENANCE	
3.1	VISUAL INSPECTION	3-1
3.2	REMOVING THE DUST COVER	3-1
3.3	CLEANING AND LUBRICATION	3-1
3.4	REPLACING THE DUST COVER	3-2
IV.	PARTS LIST	4-1

Following are registered trademarks of Electro Scientific Industries, Inc.:

ESI[®] Electro Scientific Industries, Inc.
ESIAC[®] Algebraic Computer
ESIPOT[®] Potentiometer
DEKABOX[®] Decade Resistors and Capacitors
DEKABRIDGE[®] Bridge Circuit
DEKADIAL[®] Decade Dials
DEKAMATIC[®] Automatic Unit
DEKAPOT[®] Decade Potentiometers
DEKASTAT[®] Decade Rheostat
DEKAPACITOR[®] Decade Capacitor
DEKAVIDER[®] Decade Voltage Divider
KELVIN KLAMPS[®] Four-Terminal Clamps
KELVIN KLIPS[®] Four-Terminal Clips
PORTAMETRIC[®] Portable Measuring Instrument
PVB[®] Potentiometric Voltmeter Bridge

SECTION I

DESCRIPTION AND SPECIFICATIONS

1.1 DESCRIPTION

The Model RS925A Decade Resistance Standard is a wide range, four-terminal decade resistor. The use of special ESI resistors and multiple contact, low-resistance switches in the RS925A assures high accuracy and a short term stability of better than 1 ppm.

1.2 SPECIFICATIONS

Resistance Range:	10 milliohms to 1.2 megohms provided by 8 resistance decades and a rheostat with 20 microhms resolution
Initial Adjustment Accuracy at Any Setting:	$\pm(20 \text{ ppm} + 1 \text{ milliohm})$
Short-Term Repeatability of Resistance:	Mean value of variation of total switch contact resistance less than 100 microhms
Long-Term Stability of Resistance:	Resistance will remain within $\pm(50 \text{ ppm} + 2 \text{ milliohms})$ of nominal value for more than one year.
Calibration Conditions:	23°C, four-terminal measurement
Temperature Coefficient:	
100 ohm steps and higher	$\pm 5 \text{ ppm}/^\circ\text{C}$
10 ohm steps	$\pm 15 \text{ ppm}/^\circ\text{C}$
1 ohm steps and lower	$\pm 20 \text{ ppm}/^\circ\text{C}$
Wiring and Switches	$\pm 50 \text{ microhms}/^\circ\text{C}$
Power Coefficient for Typical Measurement Duty Cycle:	
100 ohm steps and higher	$\pm 0.1 \text{ ppm/mw/step}$
10 ohm steps	$\pm 0.3 \text{ ppm/mw/step}$
1 ohm steps	$\pm 0.4 \text{ ppm/mw/step}$
0.1 and 0.01 ohm steps	$\pm 1 \text{ ppm/mw/step}$
Wiring and Switches	$\pm 50 \text{ microhms/watt total}$
Power Rating:	1 watt per step, 5 watts total, or 2 amperes maximum current
Breakdown Voltage:	1000 volts peak to case
Dimensions:	7" high, 19" long, 8" deep
Weight:	14 lbs net

RESISTANCE READING WINDOWS

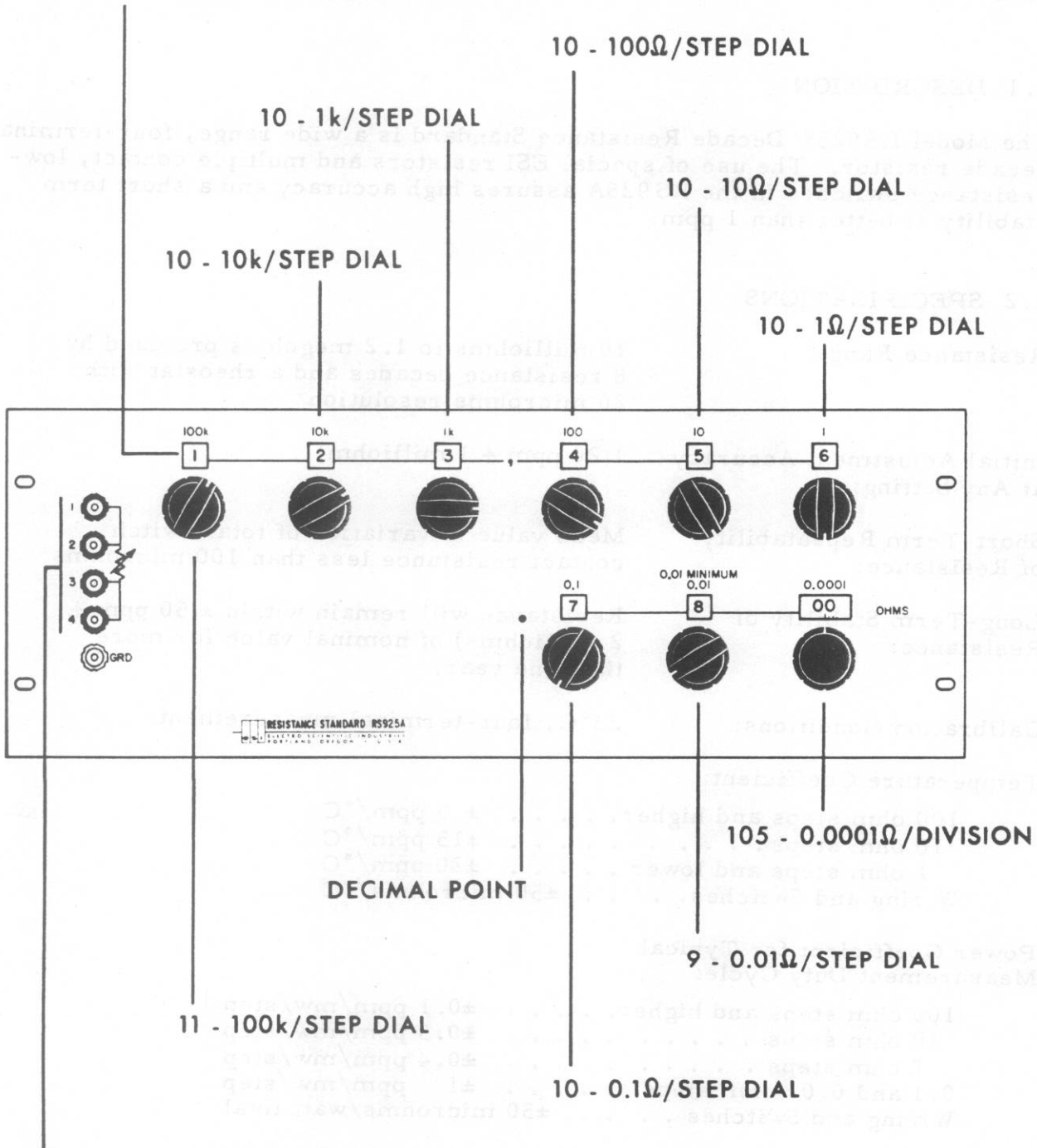

RESISTANCE TERMINALS

MODEL RS 925A PANEL CONTROLS

SECTION II

OPERATING INSTRUCTIONS

2.1 RESISTANCE SELECTION KNOBS

The first knob on the left in the top row is used to change the four-terminal resistance in steps of 100 kilohms. The successive seven knobs are used to adjust the resistance in units down to 10 milliohms. The last knob in the bottom row varies a 10.5 milliohm potentiometer which is connected as a four-terminal variable resistor. The dial reading in the window above each knob is an in-line resistance reading.

Engraved above each window is the resistance per step of that decade. A decimal point is engraved on the panel to the left of the 0.1 ohm per step decade.

The minimum reading on the 0.01 ohm per step decade is 0.01 ohm since this is the minimum internal resistance of the RS925A. An effective zero reading may be obtained on the 0.01 ohm per step dial by reducing the setting of the 0.1 ohm per step dial one position and setting the 0.01 ohm per step dial at (TEN).

2.2 RESISTANCE TERMINALS

The terminals provided permit four-terminal connection to an external circuit. The ground terminal is provided for convenience.

2.3 FOUR-TERMINAL APPLICATIONS

The ESI Model RS925A is constructed with four terminals as shown below.

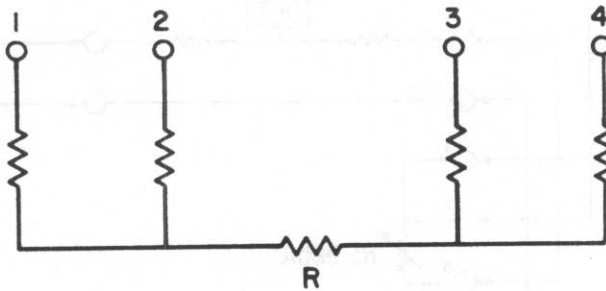

opposite end of the resistor R , and the voltage is measured between the remaining two terminals, the four-terminal resistance of R is the ratio of the measured voltage to the current. Four terminal resistors are normally used for meter shunt applications and as resistance standards for Kelvin bridge measurements.

a) Meter Shunt Applications

To measure the current in a four-terminal resistance, the voltage drop is measured between the two-terminals of the resistor not connected to the source. The current is then determined by the ratio of the measured voltage to the known resistance. Use of the four-terminal technique avoids measuring errors caused by voltage drops in the current carrying leads and contacts. Errors caused by lead and contact resistance in the voltage measuring circuit are negligible if the current in this circuit is small.

b) Kelvin Bridge Applications

A four-terminal resistance standard is used for all Kelvin bridge measurements. Errors caused by lead and contact resistances are usually negligible because they appear as part of the generator or yoke resistance, or in series with high resistance bridge arms.

For optimum performance with a Kelvin bridge connect the RS 925A terminals as follows:

1. Generator
2. Bridge (generator side)
3. Bridge (yoke side)
4. Yoke

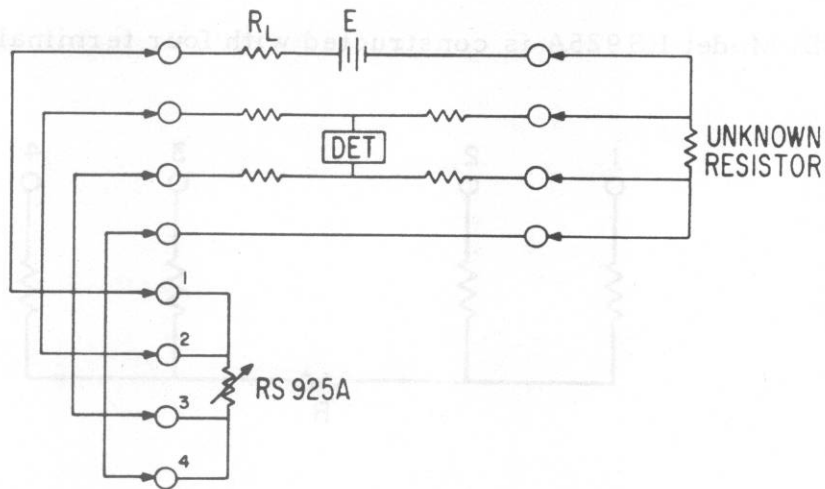

2.4 POWER LIMITATIONS

For maximum protection and accuracy it is recommended that the available power to the RS 925A Resistance Standard be limited to ONE WATT. This is accomplished by placing a resistor in series with the bridge generator or battery.

The value of this resistance can be calculated from the following formula:

$$R_L = \frac{E^2}{4}$$

where

R_L is the value of the power limiting resistor.

E is the open circuit voltage of the generator.

The protective resistor should have a power rating of 4 watts or more. Input power should be limited to 1/10 watt or less for most accurate measurements.

1.4 POWER LIMITATIONS

For maximum protection and accuracy it is recommended that the maximum power in the 2525A Resistor should be limited to 0.1 W. This is accomplished by placing a resistor in series with the signal generator or battery.

The value of this resistance can be calculated from the following formula:

$$R_L = \frac{V^2}{P}$$

where

R_L is the value of the power limiting resistor.

V is the open circuit voltage of the generator.

The protective resistor should have a power rating of a value of three times the power should be limited to 1.0 watt or less for most commercial resistors.

SECTION III

PREVENTIVE MAINTENANCE

The following procedures should be performed periodically (approximately once a year) to insure maximum accuracy and reliability from the ESI MODEL RS 925A RESISTANCE STANDARD.

If the need for major repairs is apparent, it is recommended that the unit be sent to the factory for service. The service department will be glad to furnish the necessary information for repairs as well as any replacement parts. However, unauthorized repairs will invalidate the instrument warranty. If the instrument is more than one year old when returned to the factory, a reasonable charge may be expected for replacement of parts or complete reconditioning.

3.1 VISUAL INSPECTION

Inspect the bridge for dial orientation and damage to binding posts and binding post caps. Also check for dirt around the binding post insulators. Then remove the dust cover as described in Section 3.2 and inspect the unit for possible internal defects. These defects include such things as loose or broken connections, damaged or dirty switch contacts, worn or dirty potentiometers and sliders, and heat damaged resistors.

3.2 REMOVING THE DUST COVER

Prepare a soft, clean place to set the instrument. Be sure that no projections or pointed objects will be underneath the panel. See that there are no metal filings in the area.

Remove the instrument from the rack and place it face down on the prepared surface. Loosen the screws on the back of the instrument and carefully slide the dust cover off.

3.3 CLEANING AND LUBRICATION

Clean the front panel with a soft, dry, lint-free cloth, being particularly careful to remove all dirt from around the binding post insulators. The only internal component which requires cleaning and lubrication is the potentiometer, and occasionally the switch decks. Clean and lubricate the potentiometer as follows:

CAUTION: Do not use solvents on the potentiometer. Solvents will leave a residue which may affect their performance.

- a) Polish the contact surface lightly with an abrasive cloth (Crocus cloth or equivalent).

- b) Remove loose particles by wiping with a nylon cloth.
- c) Apply a moderate amount of pure petroleum jelly to the contact surface.

The switch decks are carefully lubricated at the time of manufacture and are protected from contamination by the dust cover. They should rarely, if ever, require maintenance. It is recommended that they be cleaned or lubricated only if it is determined that they are not making good electrical contact. If the switch decks are in need of cleaning or lubrication, proceed as follows:

- a) Apply solvent (Freon printed circuit solvent or equivalent) to the contact surfaces with a small brush or pipe cleaner.
- b) Wipe surfaces with clean, dry brush or dry with low pressure air.
- c) Apply a thin coating of lubricant (Oak #2008 or equivalent) to the contact surfaces with a hypodermic needle.
- d) Apply two drops of the same oil to each of the switch bearings and detent mechanisms.
- e) Remove excess oil with a clean, dry cloth and remove all traces of lint with a soft brush.

3.4 REPLACING THE DUST COVER

Be sure that the interior of the dust cover is completely clear of all foreign material.

Slip the dust cover over the bridge being careful not to touch any resistors with the cover. Replace the screws.

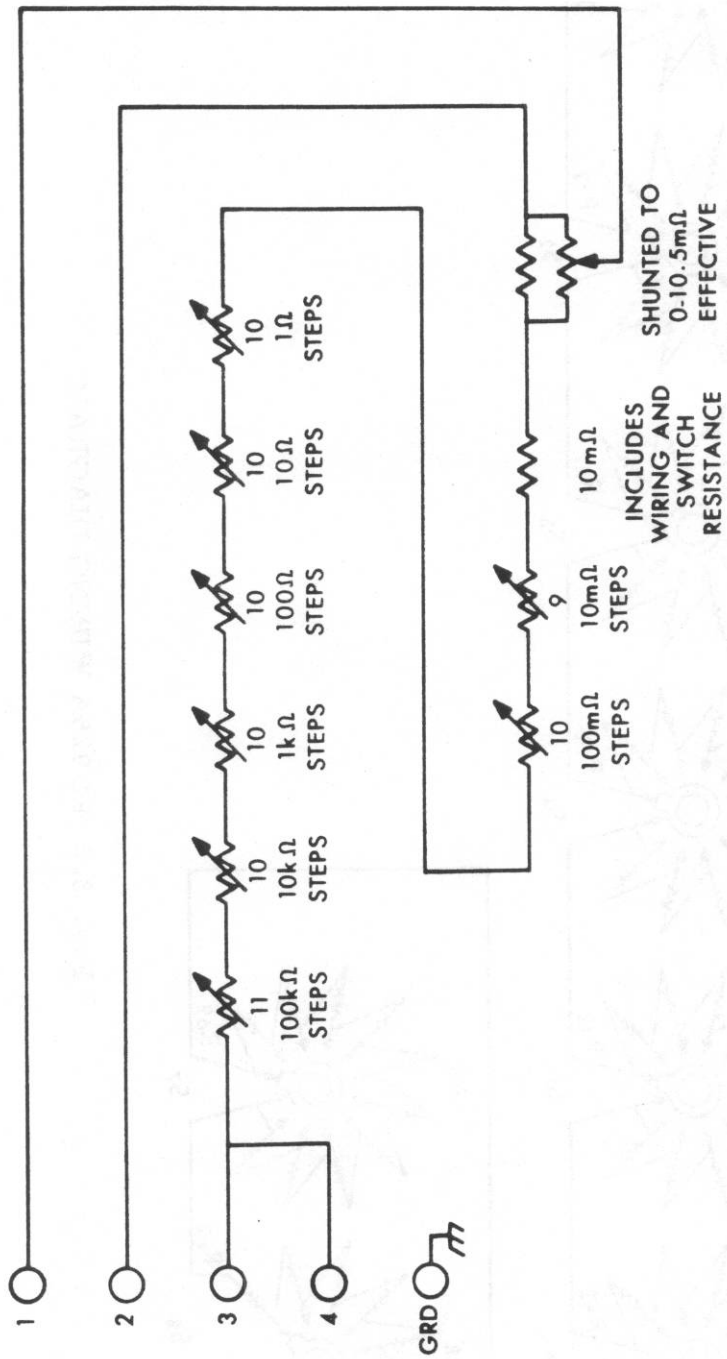

Fig. 3.1 RS925A CIRCUIT DIAGRAM

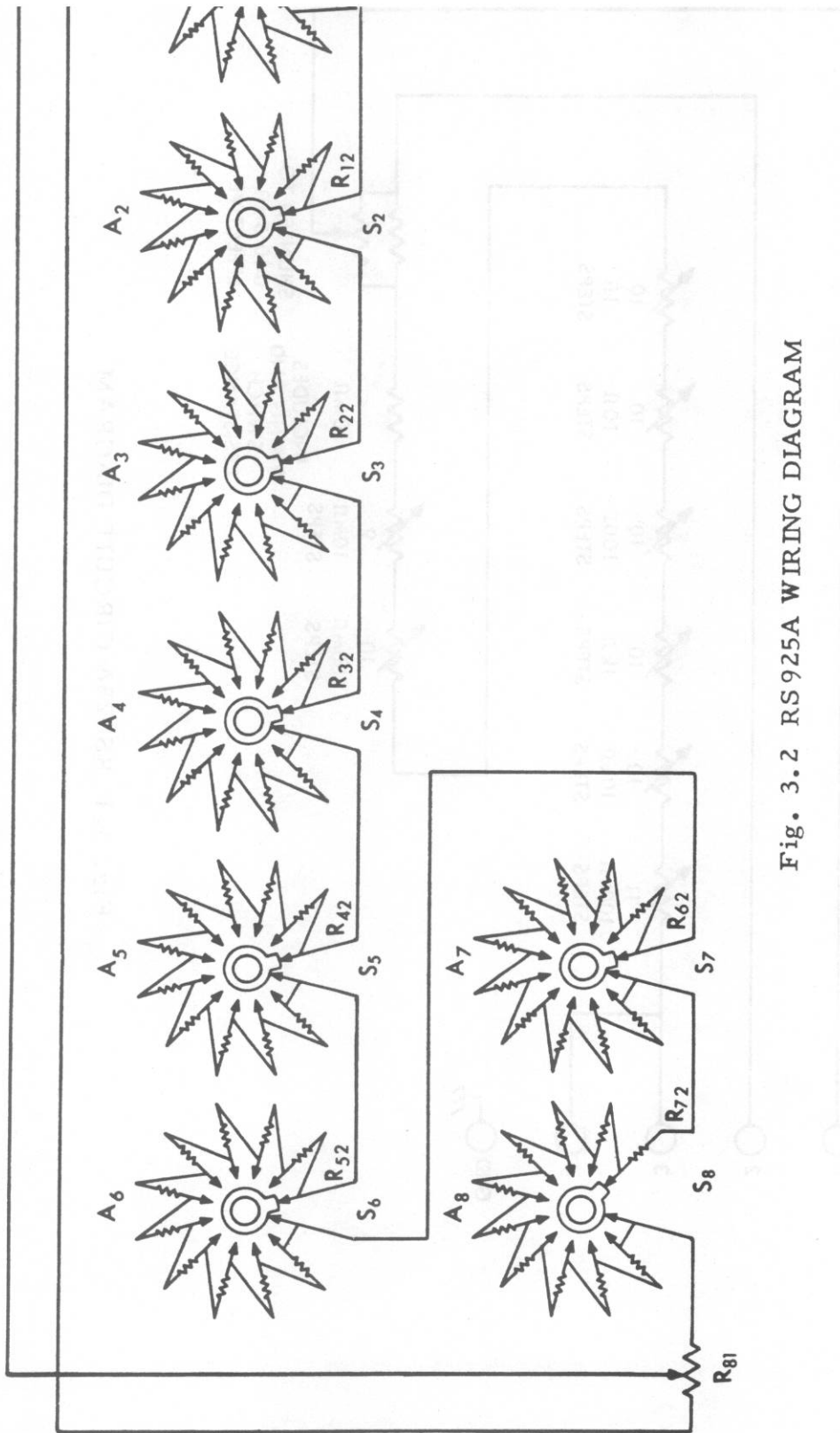

Fig. 3.2 RS925A WIRING DIAGRAM

SECTION IV

PARTS LIST

The following parts list is in alpha numerical order of the circuit reference designator. Miscellaneous parts are included at the end of the list. Manufacturer of the part is given in a code number according to the Federal Supply Code for Manufacturers; see list of manufacturers below. Parts recommended as spares to sustain operation in isolated locations are indicated in the recommended spare parts column.

Parts manufactured by Electro Scientific Industries must be ordered from the factory. When ordering parts from the factory include the following information:

Model and serial number of the instrument
 Electro Scientific Industries part number
 Circuit reference designator
 Description of part

CODE LIST OF MANUFACTURERS

11837 ELECTRO SCIENTIFIC INDUSTRIES
 Portland, Oregon

Ckt Ref	Description	Mfr.	ESI Part No.	Qty Used	Recm SP
A ₁	Assy, Sw, Res, 100K Per Step	11837	8421	1	
A ₂	Ass'y, Sw, Res, 10K Per Step	11837	8422	1	
A ₃	Ass'y, Sw, Res, 1K Per Step	11837	8423	1	
A ₄	Ass'y, Sw, Res, 100Ω Per Step	11837	8424	1	
A ₅	Ass'y, Sw, Res, 10Ω Per Step	11837	8425	1	
A ₆	Ass'y, Sw, Res, 1Ω Per Step	11837	8426	1	
A ₇	Ass'y, Sw, Res, 0.1Ω Per Step	11837	8427	1	
A ₈	Ass'y, Sw, Res, 0.01Ω Per Step	11837	8428	1	

Parts List
ESI MODEL RS-925

Ckt Ref.	Description	Mfr	ESI Part No.	Qty Used	Recm SP
R ₁ -R ₁₁	Res, Fxd, Precision, 100K, Part of Ass'y A ₁	11837	*	11	
R ₁₂ -R ₂₁	Res, Fxd, Precision, 10K, Part of Ass'y A ₂	11837	*	10	
R ₂₂ -R ₃₁	Res, Fxd, Precision, 1K, Part of Ass'y A ₃	11837	*	10	
R ₃₂ -R ₄₁	Res, Fxd, Precision, 100Ω, Part of Ass'y A ₄	11837	*	10	
R ₄₂ -R ₅₁	Res, Fxd, Precision, 10Ω, Part of Ass'y A ₅	11837	*	10	
R ₅₂ -R ₆₁	Res, Fxd, Precision, 1Ω, Part of Ass'y A ₆	11837	*	10	
R ₆₂ -R ₇₁	Res, Fxd, Precision, 0.1Ω, Part of Ass'y A ₇	11837	*	10	
R ₇₂	Res, Fxd, Factory adj to 0.01Ω including wiring and sw res	11837	*	1	
R ₇₃ -R ₈₀	Res, Fxd, Precision, 0.01Ω, Part of Ass'y A ₈	11837	*	8	
R ₈₁	Res, Variable	11837	8446	1	
S ₁	Sw, Rot., Part of Ass'y A ₁	11837	*	1	
S ₂	Sw, Rot., Part of Ass'y A ₂	11837	*	1	
S ₃	Sw, Rot., Part of Ass'y A ₃	11837	*	1	

* Replace entire ass'y

Parts List
ESI MODEL RS-925

Ckt Ref	Description	Mfr	ESI Part No.	Qty Used	Recm SP
S ₄	Sw, Rot., Part of Ass'y A ₄	11837	*	1	
S ₅	Sw, Rot., Part of Ass'y A ₅	11837	*	1	
S ₆	Sw, Rot., Part of Ass'y A ₆	11837	*	1	
S ₇	Sw, Rot., Part of Ass'y A ₇	11837	*	1	
S ₈	Sw, Rot., Part of Ass'y A ₈	11837	*	1	
<u>MISCELLANEOUS</u>					
	Dial, Decade, 2nd thru 8th	11837	7807	7	
	Dial, Decade, 1st	11837	7809	1	
	Knob, Bar	11837	1266	8	
	Knob, Round	11837	1271	1	
	Cap, Binding Post, Ins	11837	1170	4	2
	Cap, Binding Post, Metal	11837	1172	1	1
	Window, Decade	11837	7242	8	
	Window, Rheostat	11837	7789	1	
	Slider, Rheostat	11837	4196	1	1
	Reversing Drive Ass'y	11837	8817	1	
	Washer, Spring	11837	4264	1	1
	Insulator, Sw stacking bolt	11837	2326	16	

* Replace entire ass'y

MODEL 801

DC GENERATOR-DETECTOR

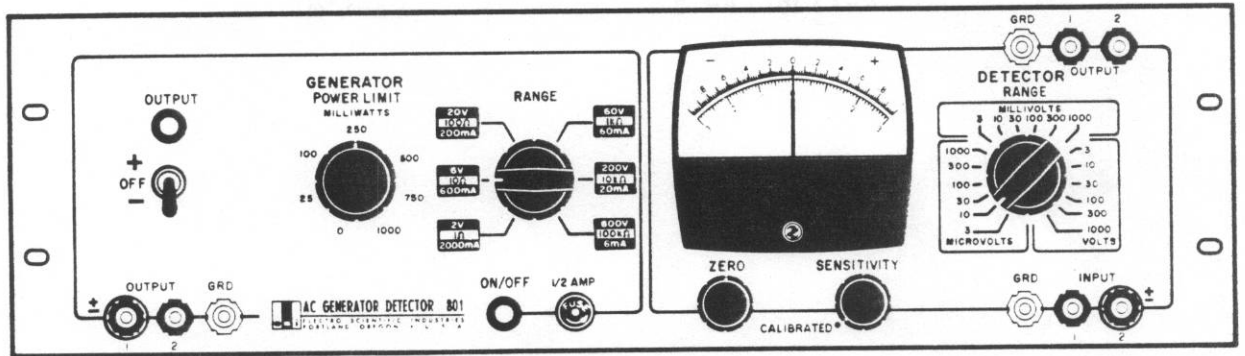

SERIAL NUMBER: _____
PART NUMBER: 18403

The following table lists the most recent revision of each page at the present printing:

<u>PAGES</u>	<u>DATE</u>
Title	3/70
A	3/70
i	2/66
ii	3/70
1-1 thru 1-4	1/66
2-1 thru 2-13	1/66
3-1 thru 3-4	1/66
4-1 thru 4-9	1/66
4-10	2/66
4-11	3/70
4-12	8/67
4-13 thru 4-15	3/70

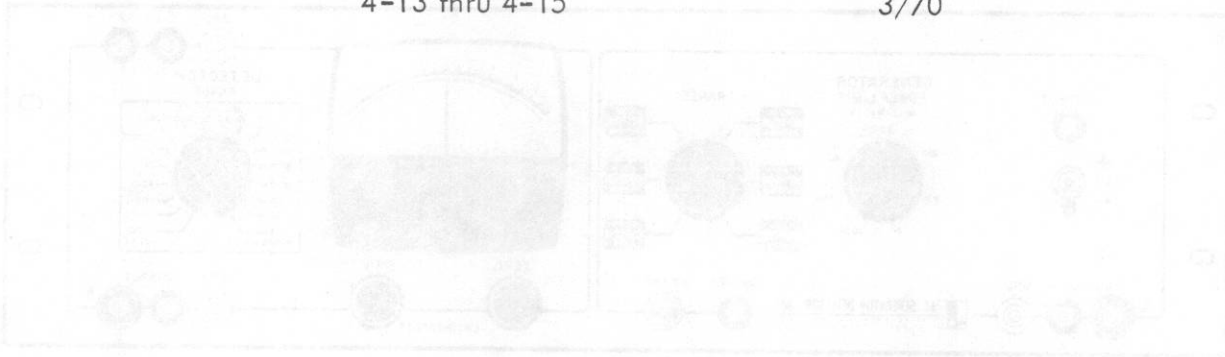

©Copyright 1966, 1967, 1970 Electro Scientific Industries, Inc.
Litho in U. S. A.

TABLE OF CONTENTS

I.	INTRODUCTION	
1.1	DESCRIPTION	1-1
1.2	SPECIFICATIONS	1-3
1.2.1	Generator	1-3
1.2.2	Detector	1-3
1.2.3	Physical	1-4
II.	OPERATING INSTRUCTIONS	
2.1	TERMINALS AND CONTROLS	2-1
2.2	BASIC OPERATING PROCEDURE	2-2
2.3	USING THE 801 FOR BRIDGE MEASUREMENTS	2-4
2.4	USING THE 801 FOR VOLTAGE DIVIDER CALIBRATION	2-5
2.5	USING THE 801 FOR TOLERANCE CHECKING BY DEFLECTION	2-6
2.6	USING THE 801 AS AN ULTRA-LOW-RESISTANCE OHMMETER	2-7
2.7	USING THE 801 AS AN ULTRA-HIGH-RESISTANCE OHMMETER	2-9
2.8	USING THE 801 AS A VOLTMETER	2-11
2.9	REMOTE GENERATOR OPERATION	2-12
2.10	CHANGING THE INPUT LINE VOLTAGE	2-13
III.	THEORY OF OPERATION	
3.1	GENERATOR	3-1
3.2	DETECTOR	3-3
IV.	MAINTENANCE	
4.1	PREVENTIVE MAINTENANCE	4-1
4.1.1	Visual Inspection	4-1
4.1.2	Removing the Case	4-1
4.1.3	Cleaning and Lubrication	4-1
4.1.4	Replacing the Case	4-2
4.2	PERFORMANCE TESTS	4-3
4.2.1	Accuracy Performance Test	4-3
4.2.2	Noise Performance Test	4-6
4.2.3	Generator Voltage Check	4-6
4.2.4	Generator Leakage Resistance Check	4-6
4.2.5	Detector Leakage Check	4-7
4.3	DETECTOR	4-8
4.3.1	Removing Inner Covers	4-8
4.3.2	Servicing Etched Circuit Boards	4-8
4.4	ADJUSTMENT AND CALIBRATION	4-9
4.4.1	Mechanical Zero Adjustment	4-9
4.4.2	Electrical Zero Adjustment	4-9
4.4.3	Full Scale Calibration	4-9
4.5	PARTS LIST	4-13

following are registered trademarks of Electro Scientific Industries, Inc.:

- ESI[®] Electro Scientific Industries, Inc.
- ESIAC[®] Algebraic Computer
- ESIPOT[®] Potentiometer
- DEKABOX[®] Decade Resistors and Capacitors
- DEKABRIDGE[®] Bridge Circuit
- DEKADIAL[®] Decade Dials
- DEKAMATIC[®] Automatic Unit
- DEKAPOT[®] Decade Potentiometers
- DEKASTAT[®] Decade Rheostat
- DEKAPACITOR[®] Decade Capacitor
- DEKAVIDER[®] Decade Voltage Divider
- KELVIN KLAMPS[®] Four-Terminal Clamps
- KELVIN KLIPS[®] Four-Terminal Clips
- PORTAMETRIC[®] Portable Measuring Instrument
- PVB[®] Potentiometric Voltmeter Bridge

ACKNOWLEDGMENTS

Thank Hewlett-Packard Company for information concerning theory of operation, schematic diagrams, and calibration and adjustment procedures for the detector. Sections 3.2, 4.2, 4.3, and 4.4 were adapted from the instruction manual for Packard Model 419A DC Null Detector by permission of Hewlett-Packard.

SECTION I

INTRODUCTION

1.1 DESCRIPTION

The ESI Model 801 is a dc generator and null detector (microvoltmeter). The instrument features double-chassis construction, or guarding, to greatly reduce stray leakage paths to ground. Leakage from the high generator terminal and from the high detector terminals to ground has been virtually eliminated. Insulation of the other terminals is kept to 10^{11} ohms or greater.

The output of the generator is continuously variable and is limited to a maximum of one watt into a matched load. A front panel control selects six output impedance ranges to match loads from 1 ohm to 100 kilohms.

An active circuit line regulator reduces the effect of line transients by a factor of more than ten. Unique guarded relays that control generator power allow remote operation of the generator. In this way, an operator can control the generator with a foot switch or the instrument can be operated by automatic equipment. The generator output terminals are short-circuited when the generator is turned off, which inhibits transient pulses at the instant of turn-on.

The detector features a very sensitive modulator-type dc amplifier. Trouble caused by stray ac pickup from the device under test is greatly reduced by a rejection filter. The modulator operates above the ac line frequency, thus further reducing the ac pickup.

The double-chassis construction and complete integrity of guarding allow either the detector or the generator to be floated more than 600 volts above ground.

The unique design features of the Model 801 make it suitable to a number of applications:

1. Very high resistance bridge measurements can be made with superior accuracy because of the special guarding and shielding features, and because of line transient reduction.
2. Very low resistance bridge measurements can also be made with high accuracy because of the detector sensitivity and the provision for matching the generator to the load.
3. The same features apply to make the 801 an ideal generator-detector combination for calibrating precision voltage dividers. A detailed description of this application may be found in ESI's "Design Ideas", volume 1, number 1. See also Section 2.4 of this Manual.
4. The 801 can be used directly to measure extremely low conductance (high resistance). See Section 2.7.

5. The 801 generator can be used separately wherever a variable, guarded, and power-limited dc supply is needed.

6. The 801 detector can be used separately as a voltmeter or microvoltmeter with ranges up to 1,000 volts.

1.2 SPECIFICATIONS

1.2.1 Generator

Range: 6 ranges, continuously variable, 0 to 600V. Power limited to 1 watt.

Regulation: Active-circuit line regulator reduces effect of line transients by a factor of more than ten.

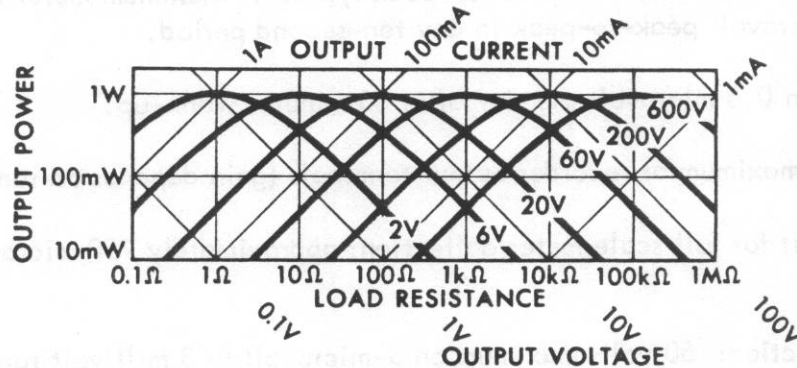

Figure 1.1 Maximum Output of 801 Generator

Insulation Resistance: Terminal 1 greater than 10^{14} ohms;
Terminal 2 greater than 10^{11} ohms;

Output Resistance:

OPEN CIRCUIT VOLTAGE (VOLTS)	2	6	20	60	200	600
SHORT CIRCUIT CURRENT (mA)	2000	600	200	60	20	6
OUTPUT RESISTANCE (OHMS)	1	10	100	1k	10k	100k

1.2.2 Detector

Ranges: Calibrated ± 3 microvolts to ± 1000 volts dc end scale in 18 zero-center ranges, sensitivity (uncalibrated) can be increased to about 0.75 microvolt end scale.

Accuracy: ± 5 percent of end scale, ± 0.1 microvolt.

Limits of Zero Control: ± 15 microvolts.

Input Resistance: 3-microvolt to 3-millivolt ranges: 100 kilohms.
10-millivolt to 30-millivolt ranges: 1 megohm.
100-millivolt to 300-millivolt ranges: 10 megohms.
1-volt to 1000-volt ranges: 100 megohms.

Response Time: 95 percent of final reading within 4 sec on the 3-microvolt range.
95 percent of final readings within 1.5 sec on the 10-microvolt to 1000-volt ranges.

Superimposed AC Rejection: With frequencies of 60 Hz (cps) or higher (except modulator frequency: 160 to 170 Hz), ac voltages that are 80 dB greater than the end scale will affect the reading less than 2 percent. (AC voltage must be limited to 300 volts rms.)

Noise: Less than 0.1 microvolt peak-to-peak typical. Maximum meter excursion will be 0.2 microvolt peak-to-peak in any ten-second period.

Drift: Less than 0.5 microvolt per day after 30 minutes warm-up.

Gain: 110 dB maximum at recorder output terminals (gain depends on range).

Output: ± 1 volt for full scale meter deflection; approximately 750 microamperes maximum.

Overload Protection: 50 volts maximum on 3-microvolt to 3 millivolt ranges; 500 volts maximum on 10-millivolt to 300-millivolt ranges; 1200 volts maximum on 1-volt range and above. Regardless of voltage limitations, the full output of the generator (approximately 600 volts) cannot damage the detector, even on the most sensitive range.

Overload Recovery Time: Meter indicates within 4 seconds for a 10^6 overload with input shorted; less than 15 seconds with input open.

Input Isolation: 10^{11} ohms shunted by 250 picofarads. May be operated more than 600 volts dc or 350 volts ac (rms) above ground.

1.2.3 Physical

Height: 5 1/4 inches (13.3 cm)

Length: 19 inches (48.25 cm)

Depth: 11 inches (25.7 cm)

Weight: 21 pounds (9.5 kg)

Power requirements: 117 or 230 volts selected by internal switch, 50 to 400 Hz (cps), 15 watts.

SECTION II

OPERATING INSTRUCTIONS

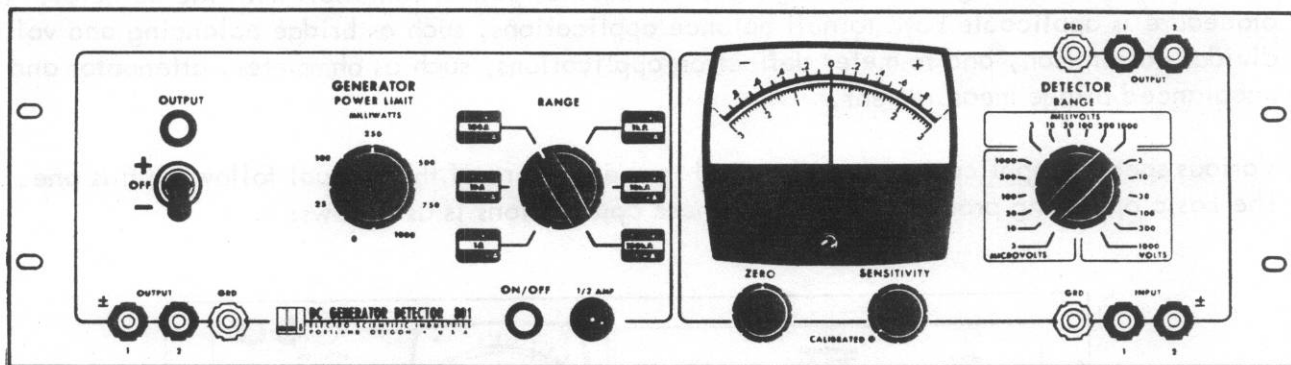

Figure 2.1 Terminals and Controls

2.1 TERMINALS AND CONTROLS

Generator OUTPUT Terminals: The lower left-hand terminals are for connecting the generator to an external circuit.

Detector INPUT Terminals: The lower right-hand terminals are for connecting the detector to an external circuit.

Detector OUTPUT Terminals: The upper right-hand terminals are provided so an external meter or recorder may be conveniently connected to the detector.

Detector ZERO Control: Adjusts the detector zero.

Detector RANGE Selector: Selects the sensitivity range of the detector.

Detector SENSITIVITY Control: Continuously varies the detector sensitivity from a minimum at the CALIBRATED position to a maximum of about four times the end-scale sensitivity indicated by the RANGE selector.

Generator POWER LIMIT Control: Varies the power limit level of the generator from 0 to 1 watt maximum.

Generator RANGE Selector: Selects the generator limiting resistor, the maximum (open circuit) voltage, and maximum (short circuit) current.

Generator OUTPUT Switch: Connects the generator output of the selected polarity to the OUTPUT terminals.

ON/OFF Switch: Controls line power to both generator and detector.

2.2 BASIC OPERATING PROCEDURE

This section describes the basic procedure for using the Model 801 to test or adjust any three-terminal or four-terminal resistive circuit by applying the generator output to one pair of terminals and observing the resulting signal at another pair of terminals with the detector. The procedure is applicable both to null balance applications, such as bridge balancing and voltage divider calibration, and to meter deflection applications, such as ohmmeter, attenuator and unbalanced bridge measurement.

Various specific applications are discussed in the sections of the manual following this one. The basic operating procedure for all of these applications is as follows:

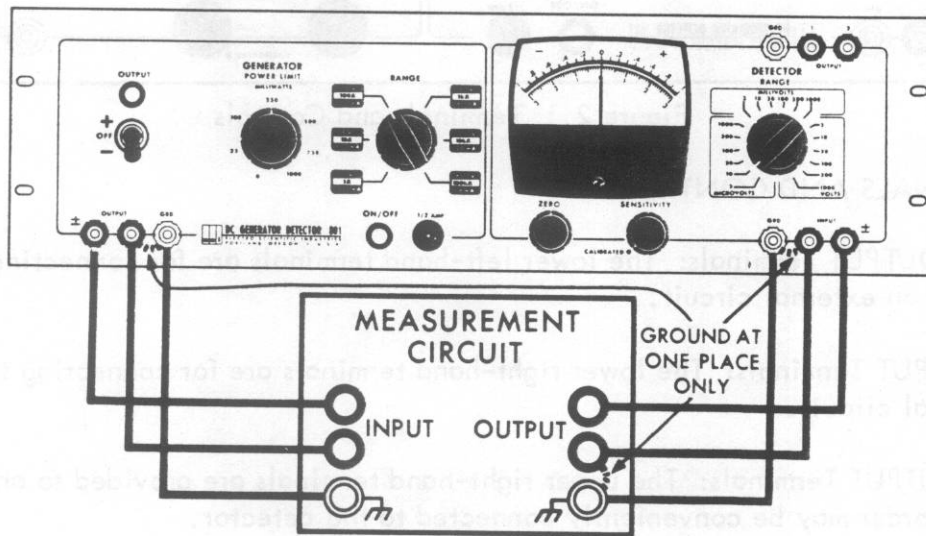

Figure 2.2 Basic Operating Procedure

1. Be sure the generator OUTPUT switch is off, then turn the ON/OFF switch on and allow time for warmup.
2. Connect the measurement circuit to the generator OUTPUT and detector INPUT terminals as shown in Figure 2.2.

The measurement circuit should be grounded at one point only, so that ground loop currents between chassis cannot flow through these leads.
3. Set the detector SENSITIVITY control at CALIBRATED.

This adjusts full scale indication to the range setting.
4. Set the detector RANGE switch at 3 microvolts and adjust the ZERO control for meter zero.

Always adjust zero with detector input connected to the measurement circuit - not open or short circuited - in order to cancel effects causing zero shift with change in source resistance.

5. Change the detector RANGE switch to a range higher than the voltage expected when the generator is first turned on.
6. Set the generator POWER LIMIT control to a value which will not cause resistance changes due to heating.
7. Set the generator RANGE control as desired.
8. Turn on the generator by setting the OUTPUT switch as desired; the marking indicates the polarity of OUTPUT terminal 1.
9. Adjust the generator POWER LIMIT and RANGE controls as required. For maximum power find the generator RANGE setting giving maximum detector deflection. To reduce the power below the generator POWER LIMIT setting, use generator RANGE settings away from the maximum setting - both voltage and current will be reduced as a result of resistance mismatch in either direction.
10. Change the detector RANGE setting as required for detector sensitivity. Use the SENSITIVITY control to increase the detector sensitivity above the calibrated detector RANGE setting.
11. Take as the final meter reading the change in reading with generator on and generator off (or half the change with generator polarity reversal), to eliminate the effect of imperfect zero adjustment.

This will avoid meter recovery delays caused by input signals greater than full scale.

A power setting lower than the lowest-rated resistor in the measurement circuit is always safe.

At a setting most nearly equal to the input resistance of the measurement circuit, the generator output will be a maximum, and will usually be approximately equal to the generator power setting.

The detector polarity is fixed, the direction of the meter deflection corresponding to the polarity of INPUT terminal 2.

For further reduction of power, connect either a low-value shunt resistor across the generator OUTPUT terminals 1 and 2 or a high-value series resistor in the OUTPUT 1 lead, and use a generator RANGE setting far away from the value of the shunt or series resistor.

Turn off the generator OUTPUT switch and recheck detector ZERO adjustment each time detector RANGE is changed toward higher sensitivity.

Take readings after switching transients have disappeared (normally within one second after turning generator on or off). For maximum sensitivity in null balance applications, generator power can often be increased for final adjustment if generator OUTPUT switch is left on only a few seconds at a time to minimize resistor heating.

2.3 USING THE 801 FOR BRIDGE MEASUREMENTS

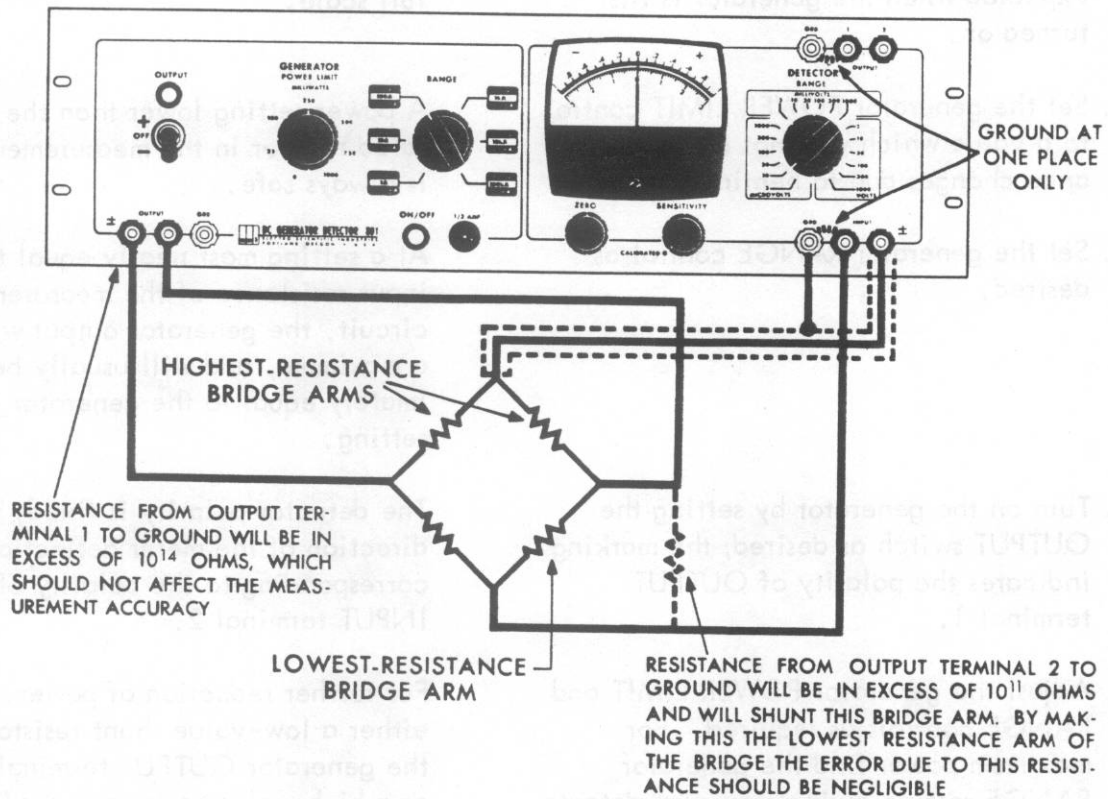

Figure 2.3 Bridge Measurement Connection

Connect the bridge to the generator OUTPUT and detector INPUT terminals as shown in Figure 2.3, then balance bridge following basic operating procedure of Section 2.2.

2.4 USING THE 801 FOR VOLTAGE DIVIDER CALIBRATION

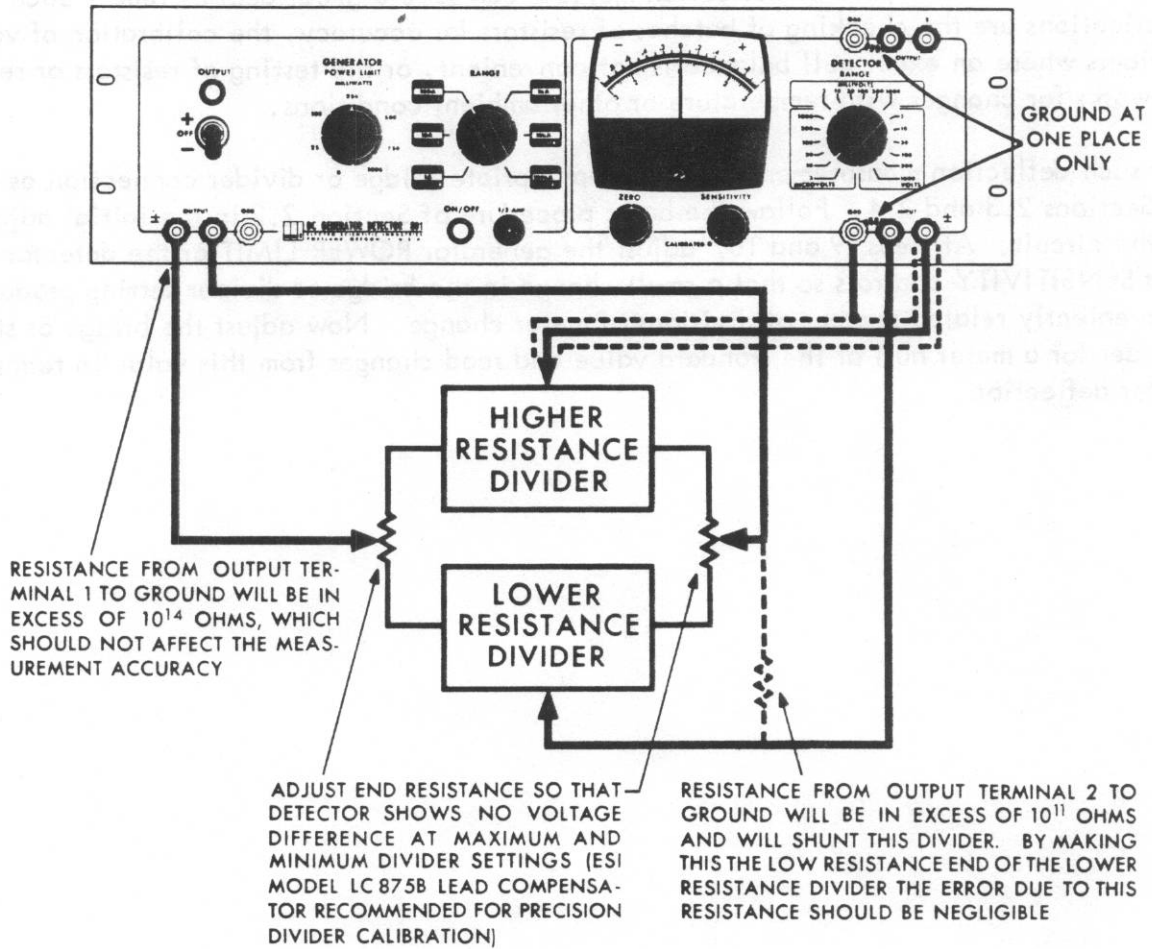

Figure 2.4 Voltage Divider Connection

Connect the pair of dividers or attenuators to the generator OUTPUT and detector INPUT terminals as shown in Figure 2.4, then adjust to find pairs of settings giving detector null indications, following the basic operating procedure of Section 2.2.

2.5 USING THE 801 FOR TOLERANCE CHECKING BY DEFLECTION

here repeated measurements are to be made to detect small variations of a resistive circuit from a standard value, meter deflection methods can save a great deal of time. Such applications are the checking of batches of resistors for accuracy, the calibration of voltage dividers where an exact null balance is not convenient, or the testing of resistors or resistive networks for changes with temperature or other ambient conditions.

For such deflection measurements, use the appropriate bridge or divider connection as discussed in Sections 2.3 and 2.4. Follow the basic procedure of Section 2.2 in the initial adjustment of the circuit. At steps 9 and 10, adjust the generator POWER LIMIT or the detector RANGE and SENSITIVITY controls so that a small change in the bridge or divider setting produces a conveniently related number of divisions of meter change. Now adjust the bridge or standard divider for a meter null at the standard value and read changes from this value in terms of meter deflection.

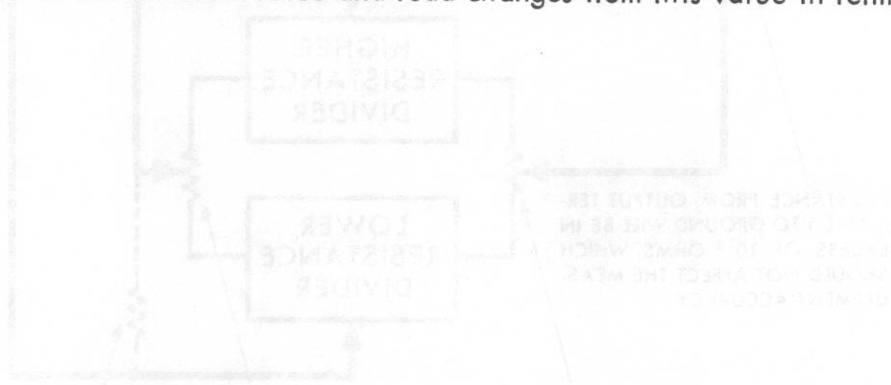

ADJUST BRIDGE OR DIVIDER SETTING TO THE DETECTOR SHOWS NO VOLTAGE DIFFERENCE AT MAXIMUM AND MINIMUM DIVIDER SETTINGS. ADJUST TO 9.99 OHMS. FOR RECORDING OF THE PRECISION DIVIDER CALIBRATION.

RESISTANCE FROM OUTPUT TERMINAL TO GROUND WILL BE IN RANGE OF 10 OHMS WHICH SHOULD NOT AFFECT THE MEASUREMENTS.

Figure 2.4 Voltage Divider Connection

Connect the positive terminal of the generator to the generator OUTPUT terminal and the negative terminal to the generator GROUND terminal. Adjust the generator output to the standard value as shown in Figure 2.2, then adjust to find the null point of the bridge or divider. Following the basic operating procedure of section 2.2, make the deflection measurements.

2.6 USING THE 801 AS AN ULTRA-LOW RESISTANCE OHMMETER

To measure the approximate value of a very low resistance, such as a switch or relay contact or a piece of wire, use the circuit shown in Figure 2.5.

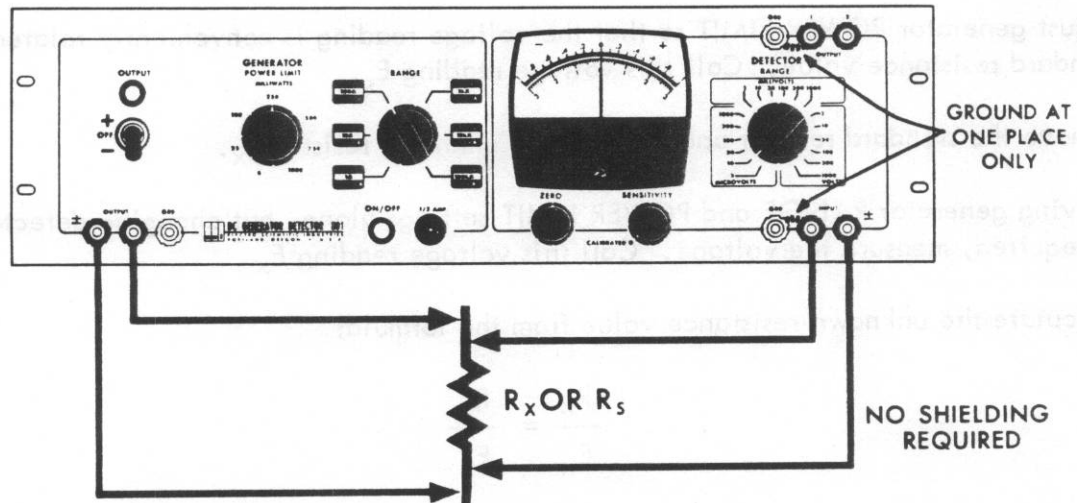

Figure 2.5 Low Resistance Measurement

Follow the basic procedure of Section 2.2 with the following additions:

For ± 20 percent accuracy:

1. Before connecting the unknown resistance, connect the detector INPUT leads directly to the generator OUTPUT leads.
2. Set the generator RANGE resistance to a value at least 10 times the value of the unknown resistor.
3. Adjust generator POWER LIMIT so that the voltage reading is an exact power of 10. Call this voltage reading E_G .
4. Connect the unknown resistor R_x in the circuit of Figure 2.5.
5. Leaving generator RANGE and POWER settings alone, but changing detector RANGE as required, measure the voltage. (Be sure that SENSITIVITY control is set to CALIBRATED.) Call this voltage reading E_x .
6. Calculate the unknown resistance value from the formula:

$$\frac{R_x}{E_x} = \frac{\text{Generator RANGE Resistance Setting}}{E_G}$$

for ±0.1 percent accuracy:

1. Connect a known standard resistor, having a value R_s not greater than 1000 ohms, in the circuit of Figure 2.5.
2. Set the generator RANGE to a value at least 100 times the value of the standard resistor.
3. Adjust generator POWER LIMIT so that the voltage reading is conveniently related to the standard resistance value. Call this voltage reading E_s .
4. Remove the standard resistor and connect the unknown resistor R_x .
5. Leaving generator RANGE and POWER LIMIT settings alone, but changing detector RANGE as required, measure the voltage. Call this voltage reading E_x .
6. Calculate the unknown resistance value from the formula:

$$\frac{R_x}{E_x} = \frac{R_s}{E_s}$$

2.7 USING THE 801 AS AN ULTRA-HIGH RESISTANCE OHMMETER

To measure the approximate value of a very high resistance, such as the leakage in an insulator, use the circuit shown in Figure 2.6.

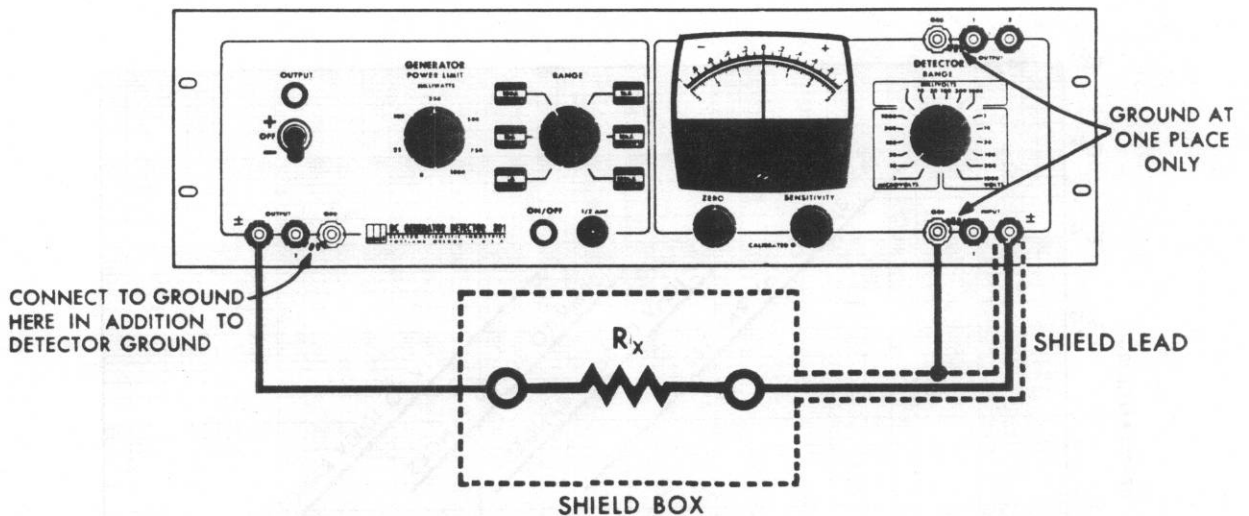

Figure 2.6 High-Resistance Measurement

Follow the basic procedure of Section 2.2 with the following additions:

1. Before connecting the unknown resistance, connect the detector INPUT 2 lead to the generator OUTPUT 1 lead (or connect a short circuit across the unknown resistance).
2. Set generator RANGE to 100 kilohms.
3. Set generator OUTPUT switch either to + or - position and adjust POWER LIMIT control for a detector reading of 500 volts. (Other voltages may be used, but the conversion chart, Figure 2.7, is intended for use with a 500-volt setting.)
4. Connect the unknown resistance R_x in the circuit of Figure 2.6.
5. Leaving the generator RANGE and POWER LIMIT settings alone, but changing detector RANGE as required, measure the voltage. Call this voltage reading E_x .
6. Use the conversion chart, Figure 2.7, to convert the voltage reading to the resistance. (If a voltage other than 500 volts was used in Step 3, use the following conversion formula:

$$R_x = \frac{E_g R_d}{E_x} - R_d$$

where R_x is the unknown resistance,
 E_g is the generator voltage,

R_D is the detector resistance, which depends on the RANGE setting:

3 MICROVOLTS to 3 MILLIVOLTS; 100 kilohms

10 MILLIVOLTS to 30 MILLIVOLTS; 1 megohm

100 MILLIVOLTS to 300 MILLIVOLTS; 10 megohms

1000 MILLIVOLTS to 1000 VOLTS; 100 megohms.)

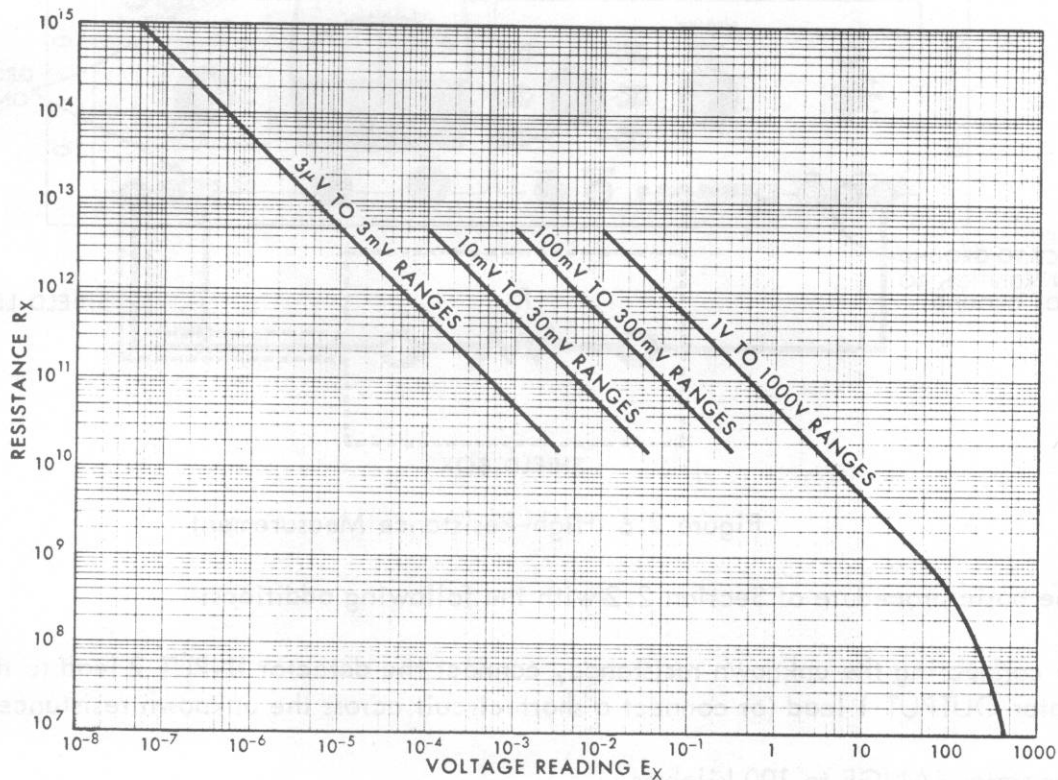
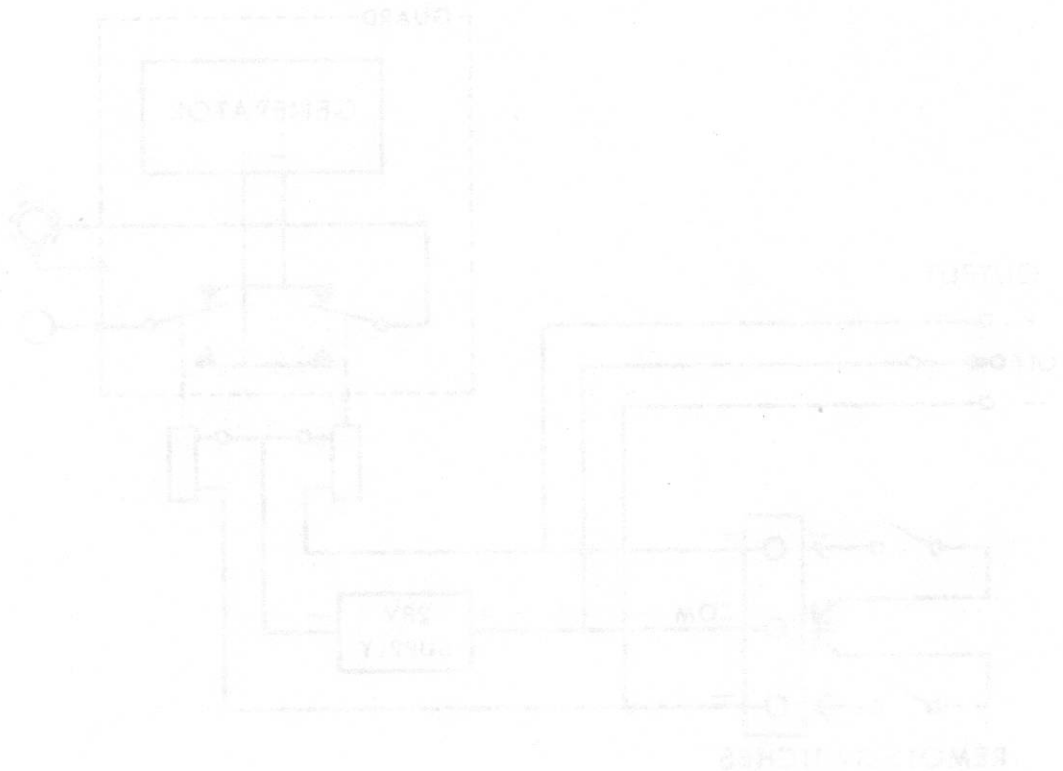

Figure 2.7 Voltage to Resistance Conversion Chart

2.8 USING THE 801 AS A VOLTMETER

To use the Model 801 detector as a voltmeter, connect the voltage to be measured to the detector INPUT terminals, set the SENSITIVITY control to CALIBRATED, and set the RANGE selector to the appropriate voltage range. If there is any doubt about the voltage, use a higher range first and then decrease it.

The voltage (times the range factor) is indicated on the meter. The polarity marked on the meter is the polarity of the voltage connected to INPUT terminal 2.



The generator output is controlled by two unique guarded relays that are controlled either by the OUTPUT switch or by remote switches. A terminal board in the back of the instrument is supplied to connect remote switches such as foot-operated switches or automatic sequencing equipment.

In order to apply a positive voltage to OUTPUT terminal 1, a remote switch must be connected to short-circuit the + and the COM terminals in the rear of the instrument. Similarly, to apply a negative voltage, a remote switch must short-circuit the - and the COM terminals.

There is no necessity to prevent simultaneous connections; if both terminals in the rear are short-circuited to COM or if, for example, the - terminal is connected to the COM terminal and the OUTPUT switch is set to +, no damage will be done since the relays will disconnect the generator when they are both energized.

Figure 2.8 is a simplified schematic of the generator control circuits.

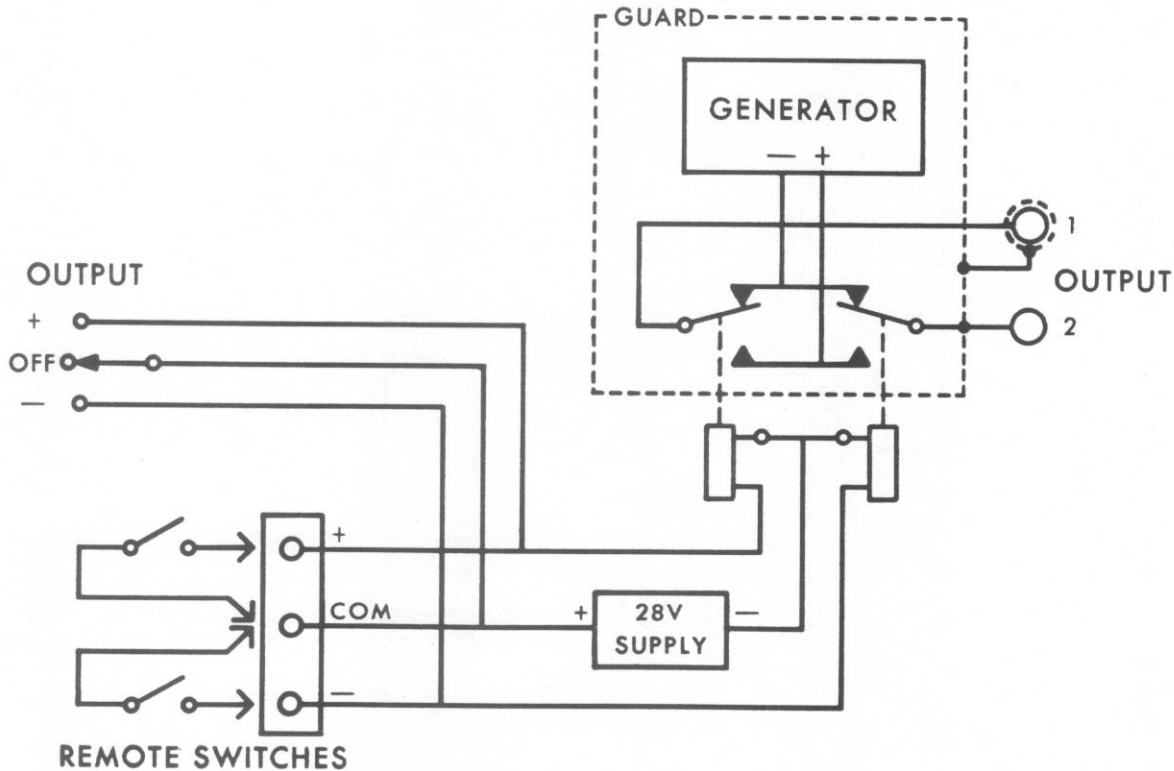

Figure 2.8 Remote Generator Control

2.10 CHANGING THE INPUT LINE VOLTAGE

The Model 801 Generator-Detector may be operated on either 117-volt or 230-volt ac power. An internal switch selects the input wiring to accommodate either voltage.

The setting of this switch at the time of manufacture is noted on the rear of the instrument. If the setting of the switch is not correct for the power line to be used, change the setting of the switch before plugging in the instrument.

In order to have access to the switch, remove the instrument case (paragraph 4.1.2). The switch is located on a chassis support immediately behind the upper center of the front panel. Slide the switch with a fingernail or with a small screwdriver so that it indicates 115 or 230 as appropriate.

Replace the instrument case after setting the switch, and correct the note attached to the rear of the instrument.

2.10 CHANGING THE INPUT LINE VOLTAGE

The Model 601 Generator-Detector may be operated on either 115-volt or 230-volt ac power. An internal switch selects the input wiring in accordance with the voltage.

The wiring of the switch of the line of manufacture is noted on the rear of the instrument. If the wiring of the switch is not correct for the power line to be used, change the wiring of the switch before plugging in the instrument.

In order to have access to the switch, remove the instrument case (paragraph 2.1.2). The switch is located on a chord support (immediately behind the upper portion of the front panel). Use the switch with a flat-head screwdriver so that it indicates 115 or 230 ac power.

Replace the instrument case after setting the switch, and connect the instrument to the rear of the instrument.

SECTION III

THEORY OF OPERATION

3.1 GENERATOR

The 801 generator is a line-regulated, guarded dc power supply with variable output power and a provision for matching the output impedance to a wide range of values. The guarding of the generator makes accurate high-resistance bridge measurements possible. The diagrams below illustrate how this is done.

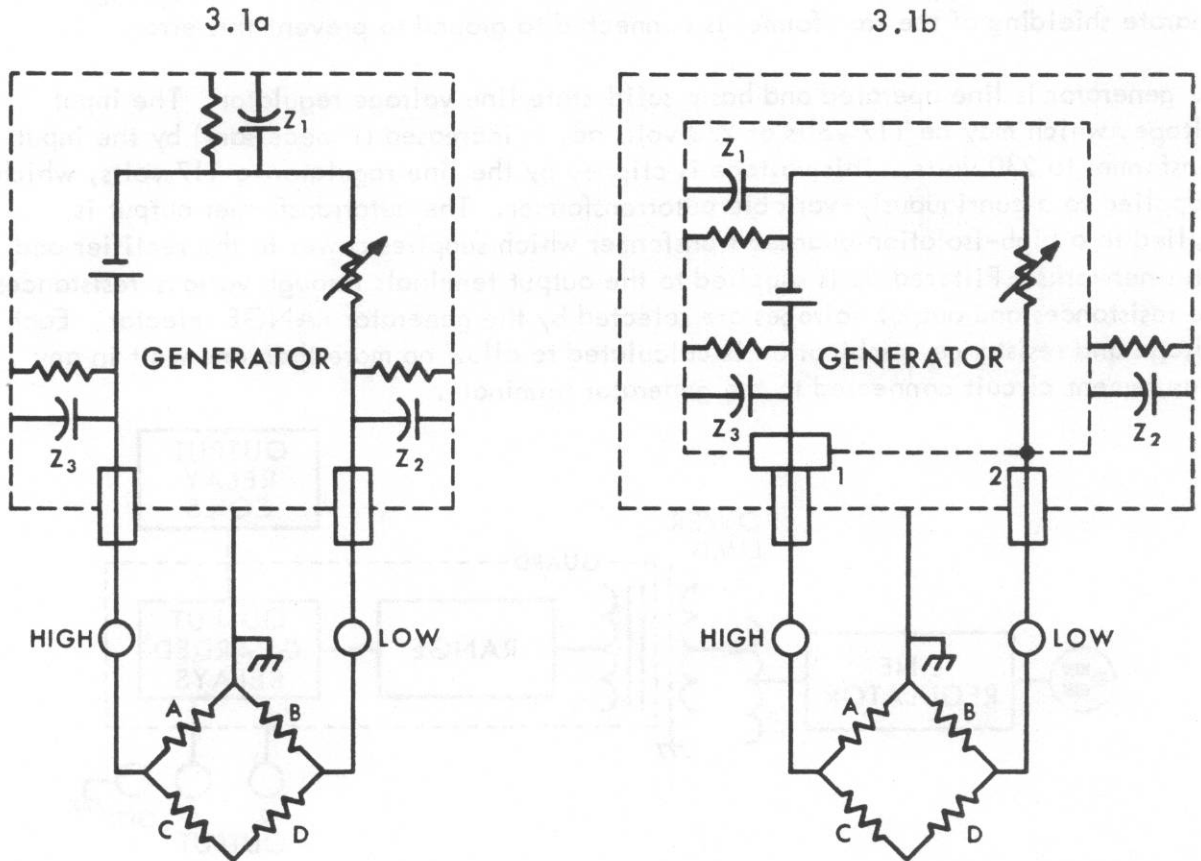

Figure 3.1 Generator Circuits

In the unguarded circuit shown in Figure 3.1a, the leakage impedances Z_2 and Z_3 appear in parallel with bridge arms A and B. If these were high-resistance arms, an appreciable error would result. The leakage impedance Z_1 is also in parallel with each of arms A and B. Since this leakage is at a higher emf than those at the terminals, it will cause even more error.

The 801 generator uses the guarded circuit as shown in Figure 3.1b. Z_1 and Z_3 appear in parallel with the generator, and cause no trouble. Z_2 is kept to better than 10^{11} ohms by use of high quality insulators, both as a feed-through insulator for the low terminal and as

support insulators for the guard chassis. By keeping bridge arm B (or whatever resistance is attached to the low terminal) small relative to 10^{11} ohms, no appreciable error is experienced. The guarding also keeps any ac voltage across Z_1 from getting into the detector via bridge arms A and B, since this ac voltage is returned to the low terminal.

The primary of the power transformer is separately shielded and air-insulated from the core to prevent capacitive coupling and leakage of ac voltages to the guard chassis. If an ac voltage were present on the guard chassis, it would appear from the low output terminal to ground and, thus, directly across the bridge arm B (Figure 3.1) in bridge measurements. The ac would then appear on the detector and would cause an error in null reading. The separate shielding of the transformer is connected to ground to prevent this error.

The generator is line-operated and has a solid-state line voltage regulator. The input voltage, which may be 117 volts or 230 volts ac, is increased (if necessary) by the input transformer to 230 volts. This voltage is clipped by the line regulator to 117 volts, which is applied to a continuously-variable autotransformer. The autotransformer output is applied to a high-isolation guarded transformer which supplies power to the rectifier and filter networks. Filtered dc is supplied to the output terminals through various resistances. The resistances and output voltages are selected by the generator RANGE selector. Each voltage and resistance combination is calculated to allow no more than one watt in any measurement circuit connected to the generator terminals.

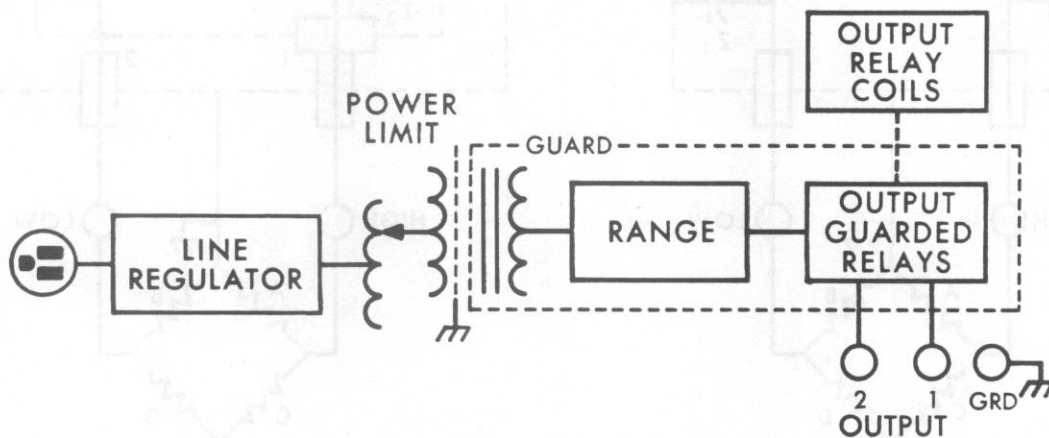

Figure 3.2 Generator Simplified Circuit

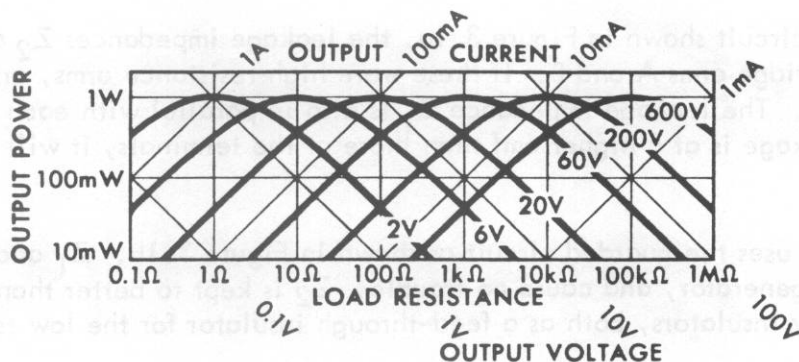

Figure 3.3 Generator Output

3.2 DETECTOR

The detector of the Model 801 is a high-sensitivity solid-state dc voltmeter. It has the following basic circuits: (1) an input attenuator, (2) a modulator and demodulator, (3) an ac amplifier, (4) a dc amplifier, (5) a meter, and (6) a feedback control circuit. Figure 3.4 is a block diagram of the detector.

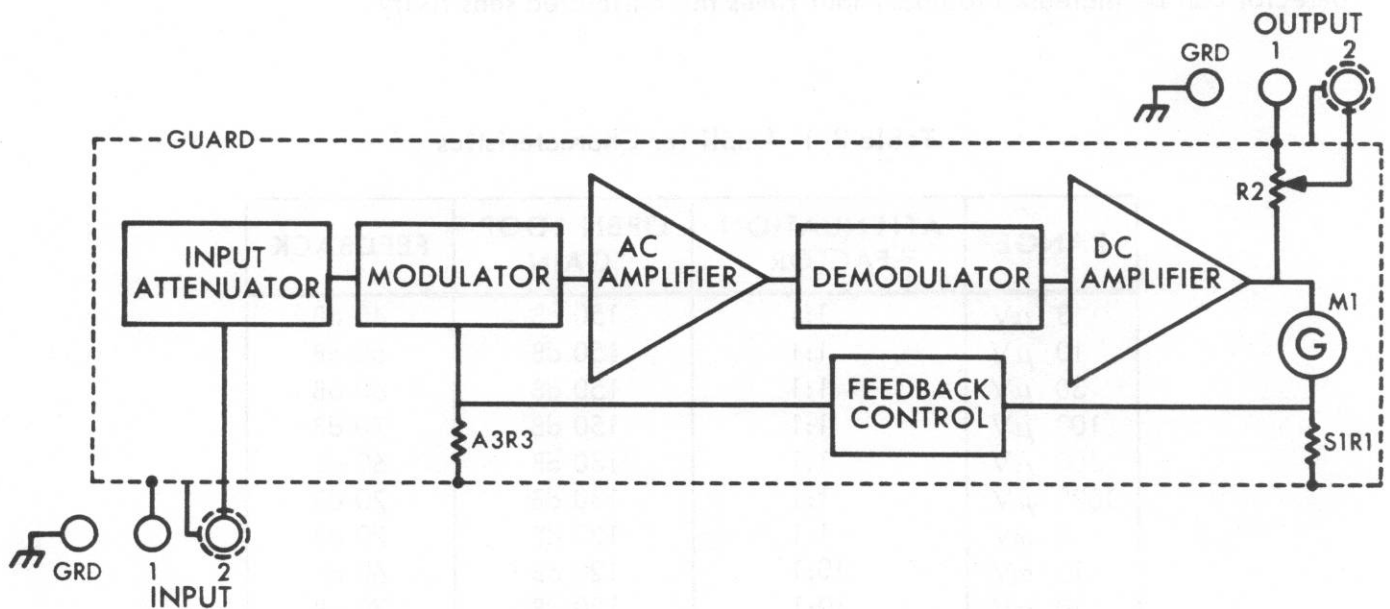

Figure 3.4 Detector Block Diagram

A dc voltage measured by the detector is applied to the input attenuator, which is a resistive divider operated by the RANGE switch. Table 3.1 lists the attenuation factors for each range.

The dc output of the input attenuator is modulated by the modulator, which consists of two photocells that are alternately illuminated by two neon lamps. The output of the modulator is a square wave with an amplitude that is proportional to the amplitude of the dc input voltage.

The square wave output of the modulator is amplified by a six-stage, high-gain ac amplifier. The output of the ac amplifier is applied to the demodulator. The demodulator output is a dc voltage with an amplitude proportional to the square-wave output of the ac amplifier. The output of the demodulator is applied to a three-stage dc voltage and power amplifier. The gain provided by the ac and dc amplifiers is listed for each range in Table 3.1.

The output of the dc amplifier, approximately 1 volt full scale, is applied to the meter and to the OUTPUT terminals on the front of the panel.

The feedback control circuit consists of a resistive voltage divider controlled by the RANGE switch and a SENSITIVITY control. When the SENSITIVITY control is in the CALIBRATED

position, it is disconnected, and only the voltage divider has any effect. The feedback provided by the feedback control circuit with SENSITIVITY at CALIBRATED is listed for each range in Table 3.1. Subtracting the feedback from the open-loop gain gives the closed-loop gain. The closed-loop gain, in conjunction with the input attenuation factor provides 18 calibrated full scale ranges from 3 microvolts to 1000 volts. When the SENSITIVITY control is not in the CALIBRATED position, it reduces the feedback and thus increases the closed-loop gain. By thus reducing the feedback, the sensitivity of the detector can be increased to about four times the calibrated sensitivity.

Table 3.1 Amplifier Characteristics

RANGE	ATTENUATION FACTOR	OPEN LOOP GAIN	FEEDBACK
3 μ V	1:1	150 dB	40 dB
10 μ V	1:1	150 dB	50 dB
30 μ V	1:1	150 dB	60 dB
100 μ V	1:1	150 dB	70 dB
300 μ V	1:1	130 dB	60 dB
1000 μ V	1:1	130 dB	70 dB
3 mV	1:1	120 dB	70 dB
10 mV	10:1	120 dB	60 dB
30 mV	10:1	120 dB	70 dB
100 mV	10 ² :1	120 dB	60 dB
300 mV	10 ² :1	120 dB	70 dB
1000 mV	10 ³ :1	120 dB	60 dB
3 V	10 ³ :1	120 dB	70 dB
10 V	10 ⁴ :1	120 dB	60 dB
30 V	10 ⁴ :1	120 dB	70 dB
100 V	10 ⁵ :1	120 dB	60 dB
300 V	10 ⁵ :1	120 dB	70 dB
1000 V	10 ⁶ :1	120 dB	60 dB

SECTION IV

MAINTENANCE

4.1 PREVENTIVE MAINTENANCE

The following procedures should be performed periodically (approximately once a year) to insure maximum accuracy and reliability from the Model 801 Generator-Detector.

If the need for major repairs is apparent, it is recommended that the unit be sent to the factory for service. The service department will be glad to furnish the necessary information for repairs as well as any replacement parts. However, unauthorized repairs will invalidate the instrument warranty.

4.1.1 Visual Inspection

Inspect the unit for dial orientation and damage to binding posts and binding post caps. Also check for dirt around the binding post insulators. Then remove the case as described in Paragraph 4.1.2 and inspect the unit for possible internal defects. These defects include such things as loose or broken connections, damaged or dirty switch contacts, and heat-damaged resistors.

4.1.2 Removing the Case

Prepare a soft, clean place to set the instrument. Be sure that no projections or pointed objects will be underneath the panel. See that there are no metal filings in the area.

Place the unit face down on the prepared surface. Remove the screws on the back of the instrument and carefully slide the case off.

4.1.3 Cleaning and Lubrication

Clean the front panel with a soft, dry, lint-free cloth, being particularly careful to remove all dirt from around the binding post insulators. The only internal components that require cleaning and lubrication are the switches.

The switches are carefully lubricated at the time of manufacture and are protected from contamination by the instrument case. They should rarely, if ever, require maintenance. It is recommended that they be cleaned or lubricated only if it is determined that they are not making good electrical contact. If the switch decks are in need of cleaning or lubrication, proceed as follows:

- a) Apply solvent (Freon printed circuit solvent or equivalent) to the contact surfaces with a small brush or pipe cleaner.
- b) Wipe surfaces with clean, dry brush or dry with low-pressure air.

- c) Apply a thin coating of lubricant (Oak #2008 or equivalent) to the contact surfaces with a hypodermic needle.
- d) Apply two drops of the same oil to each of the switch bearings and detent mechanisms.
- e) Remove excess oil with a clean, dry cloth and remove all traces of lint with a soft brush.

4.1.4 Replacing the Case

Be sure that the interior of the case is completely clear of all foreign material. Slip the case over the unit and replace the screws.

4.2 PERFORMANCE TESTS

The performance tests presented in this section are front panel procedures designed to compare the Model 801 with its published specifications. These tests may be incorporated in periodic maintenance, post repair, and incoming quality control inspection. These tests should be conducted before any attempt is made at instrument calibration.

The test equipment required for maintenance of the Model 801 is listed in Table 4.1. Equipment having similar characteristics may be substituted for the equipment listed.

Table 4.1 Test Equipment Required

INSTRUMENT TYPE	REQUIRED CHARACTERISTICS	USE	RECOMMENDED MODEL
Potentiometric Voltmeter	DC Voltage Range: 1 μ V to 500 V Accuracy: $\pm 0.2\%$	Accuracy Test, Response Test, and Alignment	ESI Model 300 PVB [®]

4.2.1 Accuracy Performance Test

The accuracy performance test setup is illustrated in Figure 4.1.

- a) Connect test setup illustrated in Figure 4.1a and set potentiometric voltmeter to operate as a voltage source.
- b) Make control settings indicated in Step 1 of Table 4.2. If detector reading is not within tolerances listed, perform full-scale calibration procedure (paragraph 4.4.3).
- c) Repeat Step b for Steps 1 through 13 in Table 4.2.
- d) Connect a wire from generator OUTPUT terminal 1 to detector INPUT terminal 2, and a wire from generator OUTPUT terminal 2 to detector INPUT terminal 1. See Figure 4.1b.
- e) Set the potentiometric voltmeter to measure voltage.
- f) Make the control settings indicated in Step 14 of Table 4.2 and adjust generator POWER LIMIT and RANGE controls to null the potentiometric voltmeter. If detector reading is not within tolerances listed, perform full-scale calibration procedure (paragraph 4.4.3).
- g) Repeat Step f for Steps 14 through 18 in Table 4.2.

Table 4.2 Accuracy Performance Test

STEP	POTENTIOMETRIC VOLTMETER SETTINGS		MODEL 801	
	MULTIPLIER	DECADE DIALS	DETECTOR RANGE	DETECTOR READING
1	VOLTS × 0.01	0.0003	3 μV	2.75 to 3.35
2	VOLTS × 0.1	0.0001	10 μV	9.40 to 10.60
3	VOLTS × 0.1	0.0003	30 μV	2.84 to 3.16
4	VOLTS × 0.1	0.0010	100 μV	9.49 to 10.51
5	VOLTS × 0.1	0.0030	300 μV	2.85 to 3.15
6	VOLTS × 1	0.0010	1000 μV	9.50 to 10.50
7	VOLTS × 1	0.0030	3 mV	2.85 to 3.15
8	VOLTS × 1	0.0100	10 mV	9.50 to 10.50
9	VOLTS × 1	0.0300	30 mV	2.85 to 3.15
10	VOLTS × 1	0.1000	100 mV	9.50 to 10.50
11	VOLTS × 1	0.3000	300 mV	2.85 to 3.15
12	VOLTS × 1	1.0000	1000 mV	9.50 to 10.50
13	VOLTS × 1	3.0000	3 V	2.85 to 3.15
14	VOLTS × 10	1.0000	10 V	9.50 to 10.50
15	VOLTS × 10	3.0000	30 V	2.85 to 3.15
16	VOLTS × 100	1.0000	100 V	9.50 to 10.50
17	VOLTS × 100	3.0000	300 V	2.85 to 3.15
18	VOLTS × 100	5.0000	1000 V	4.50 to 5.50

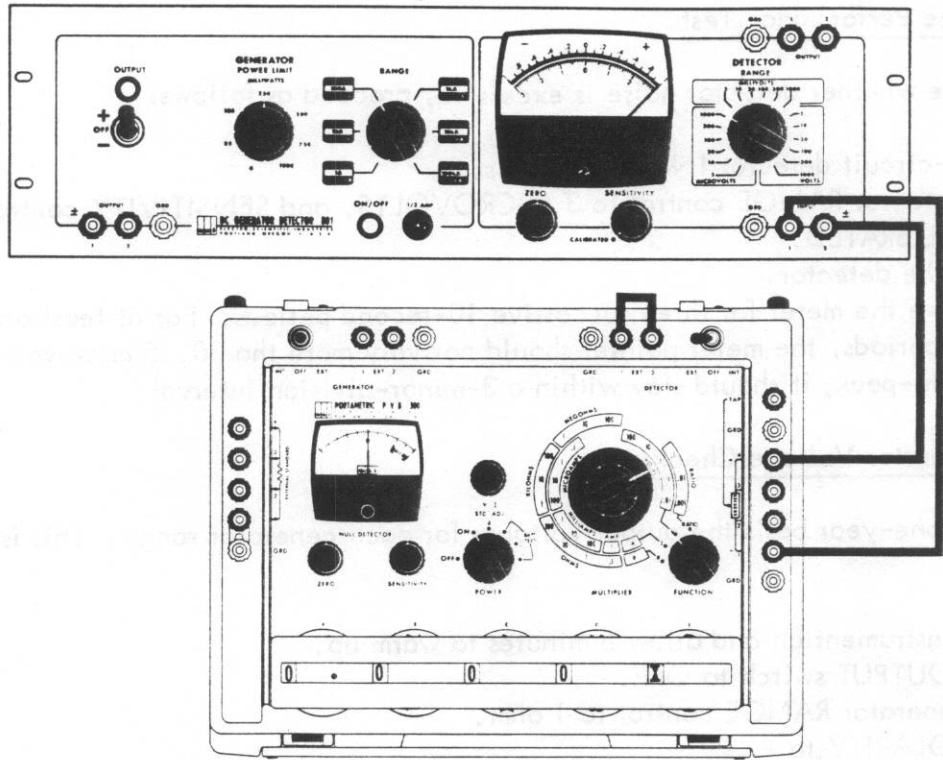

Figure 4.1a Detector Accuracy Test

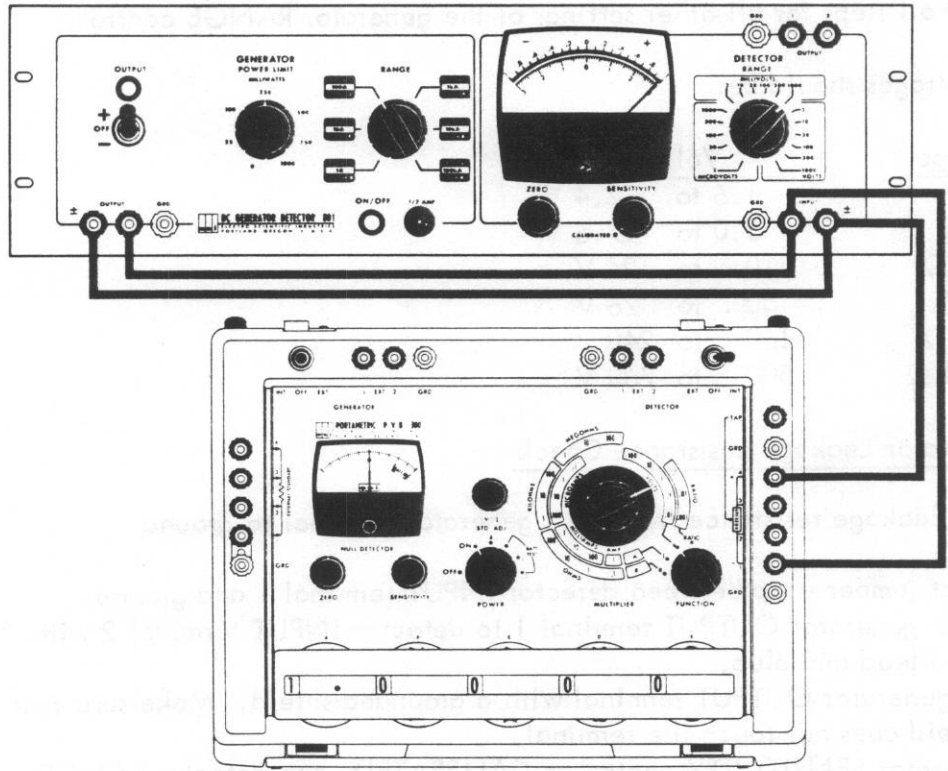

Figure 4.1b Detector Accuracy Test

Use Performance Test

1. If detector noise is excessive, proceed as follows:

1.1 Turn OFF circuit detector INPUT terminals.

1.2 Turn detector RANGE control to 3 MICROVOLTS, and SENSITIVITY control to CALIBRATED.

1.3 Turn OFF the detector.

1.4 Turn the meter for three successive 10-second periods. For at least one of these periods, the meter pointer should not vary more than 0.15 microvolt peak-to-peak; it should stay within a 3-minor-division interval.

Generator Voltage Check

1. On a one-year basis the output voltages for each generator range. This is done

1.1 Turn the instrument on and allow 5 minutes to warm up.

1.2 Turn OUTPUT switch to OFF.

1.3 Turn generator RANGE control to 1 ohm.

1.4 Turn POLARITY to + .

1.5 Connect detector INPUT to generator OUTPUT terminals.

1.6 Turn generator POWER LIMIT control to maximum.

1.7 Measure voltage using the detector as a voltmeter.

1.8 Repeat all steps for all other settings of the generator RANGE control.

2. Output voltages should be:

Range	Voltage	
2	1.6 to	2.4 V
Ω	5.0 to	7.6 V
0 Ω	10 to	24 V
Ω	50 to	76 V
k Ω	160 to	240 V
0k Ω	500 to	760 V

Generator Leakage Resistance Check

1. Measure leakage resistance from each generator terminal to ground:

1.1 Connect jumper strap between detector INPUT terminal 1 and ground.

1.2 Connect generator OUTPUT terminal 1 to detector INPUT terminal 2 with shielded lead and plug.

1.3 Shield generator OUTPUT terminal with a grounded shield. Make sure that the shield does not touch the terminal.

1.4 Turn detector SENSITIVITY control to CALIBRATED, and detector RANGE control to 10 MILLIVOLTS.

5. Set generator RANGE to 600 V, turn POWER LIMIT control fully clockwise, and set OUTPUT switch to + .
6. Meter should indicate less than 600 millivolts. (This indicates resistance greater than 10^{11} ohms.)
7. Set OUTPUT switch to OFF and connect generator OUTPUT terminal 2 to detector INPUT terminal 2 using shielded cable and plug. Again, as in test above, do not let plug touch terminal.
8. Set detector RANGE to 3 MICROVOLTS and generator RANGE to 600 V.
9. Set generator OUTPUT switch to + and turn POWER LIMIT control fully counterclockwise. Do not be concerned if meter indication goes off scale; it should be back on scale in a few seconds.
10. Within 30 seconds, the meter should indicate not more than 0.6 microvolt. (This indicates resistance greater than 10^{14} ohms.)

4.2.5 Detector Leakage Check

To check leakage resistance from each detector terminal to ground:

1. Disconnect any ground strap or jumper between either detector INPUT or OUTPUT terminals and ground.
2. Connect a jumper strap between generator OUTPUT terminal 2 and ground.
3. Connect generator OUTPUT terminal 1 to detector INPUT terminal 2 with a shielded lead and plug.
4. Cover detector INPUT terminal 1 with a grounded shield. Make sure that the shield does not touch the terminal.
5. Set detector SENSITIVITY control to CALIBRATED, and detector RANGE to 1000 MILLIVOLTS.
6. Turn generator RANGE and POWER LIMIT controls fully clockwise, and set OUTPUT switch to + .
7. Meter should indicate less than 600 millivolts. (This indicates resistance greater than 10^{11} ohms.)
8. Set OUTPUT switch to OFF and connect generator OUTPUT terminal 2 to detector INPUT terminal 1 using shielded cable and plug.
9. Set detector RANGE to 3 MICROVOLTS and generator RANGE to 600 V.
10. Set generator OUTPUT switch to + and turn POWER LIMIT control fully counterclockwise. Do not be concerned if meter indication goes off scale; it should be back on scale in a few seconds.
11. Within 30 seconds, the meter should indicate not more than 0.6 microvolt. (This indicates resistance greater than 10^{14} ohms.)

DETECTOR

1.3.1 Removing Inner Covers

The generator and the detector have inner covers to provide complete guarding and shielding of components. To remove the generator covers (top and bottom), remove the four screws holding each cover plate. To remove the detector cover, remove the two screws on the rear of the cover and slide the U-shaped cover backward, being careful not to scrape the circuit boards.

1.3.2 Servicing Etched Circuit Boards

CAUTION

REMOVE THE FIVE COLORED WIRES FROM
THE CIRCUIT CARDS IN THE DETECTOR
BEFORE UNPLUGGING THE CARDS.

The Model 801 has etched circuit boards. Use caution when removing them to avoid damaging mounted components. The assembly and Hewlett-Packard or ESI part number are on the circuit board to identify it.

The detector etched circuit boards are a plated-through type. The electrical connection between sides of the board is made by a layer of metal plated through the component holes. When working on these boards, observe the following general rules:

- a) Use a low-heat (25 to 50 watts) small-tip soldering iron and a small-diameter rosen-core solder.
- b) Circuit components can be removed by placing the soldering iron on the component lead on either side of the board and pulling up on lead. If a component is obviously damaged, clip leads as close to component as possible and then remove. Excess heat can cause the circuit and board to separate or cause damage to the component.
- c) Component lead hole should be cleaned before inserting new lead.
- d) To replace components, shape new leads and insert them in holes. Reheat with iron and add solder as required to insure a good electrical connection.
- e) Clean excess flux from the connection and adjoining area.
- f) To avoid surface contamination of the printed circuit, clean with weak solution of warm water and mild detergent after repair. Rinse thoroughly with clean water. When completely dry, spray lightly with Krylon (#1302 or equivalent).

4.4 ADJUSTMENT AND CALIBRATION

4.4.1 Mechanical Zero Adjustment

The mechanical zero adjustment is located on the instrument front panel. If the meter pointer does not indicate zero when the instrument power has been off for at least one minute, mechanically zero the meter by turning the screwdriver adjustment on the meter.

4.4.2 Electrical Zero Adjustment

The electrical zero adjustment should be performed when the meter pointer does not indicate zero on the 1000-millivolt range when instrument power has been on for at least one minute. No external equipment is required for this adjustment.

- a) Set detector RANGE control to 1000 MILLIVOLTS.
- b) Short-circuit INPUT terminals.
- c) Remove the case; adjust A1R14 (1 V ZERO) for zero deflection on meter.

4.4.3 Full-Scale Calibration

The full-scale calibration consists of performing the $3\ \mu\text{V}$, $10\ \mu\text{V}$, 1 mV and 1 V adjustments.

- a) Connect test setup illustrated in Figure 4.1a.
- b) Remove the case
- c) Set Potentiometric Voltmeter for $3\ \mu\text{V}$ output; adjust A1R41 ($3\ \mu\text{V}$) for full-scale deflection on $3\ \mu\text{V}$ range.
- d) Set Potentiometric Voltmeter for $10\ \mu\text{V}$ output; adjust A1R42 ($10\ \mu\text{V}$) for full-scale deflection on $10\ \mu\text{V}$ range.
- e) Set Potentiometric Voltmeter for 1 mV output; adjust A1R43 (1 MV) for full-scale deflection on 1000 μV range.
- f) Set Potentiometric Voltmeter for 1 V output; adjust A1R44 (1 V) for full-scale deflection on 1000 mV range.

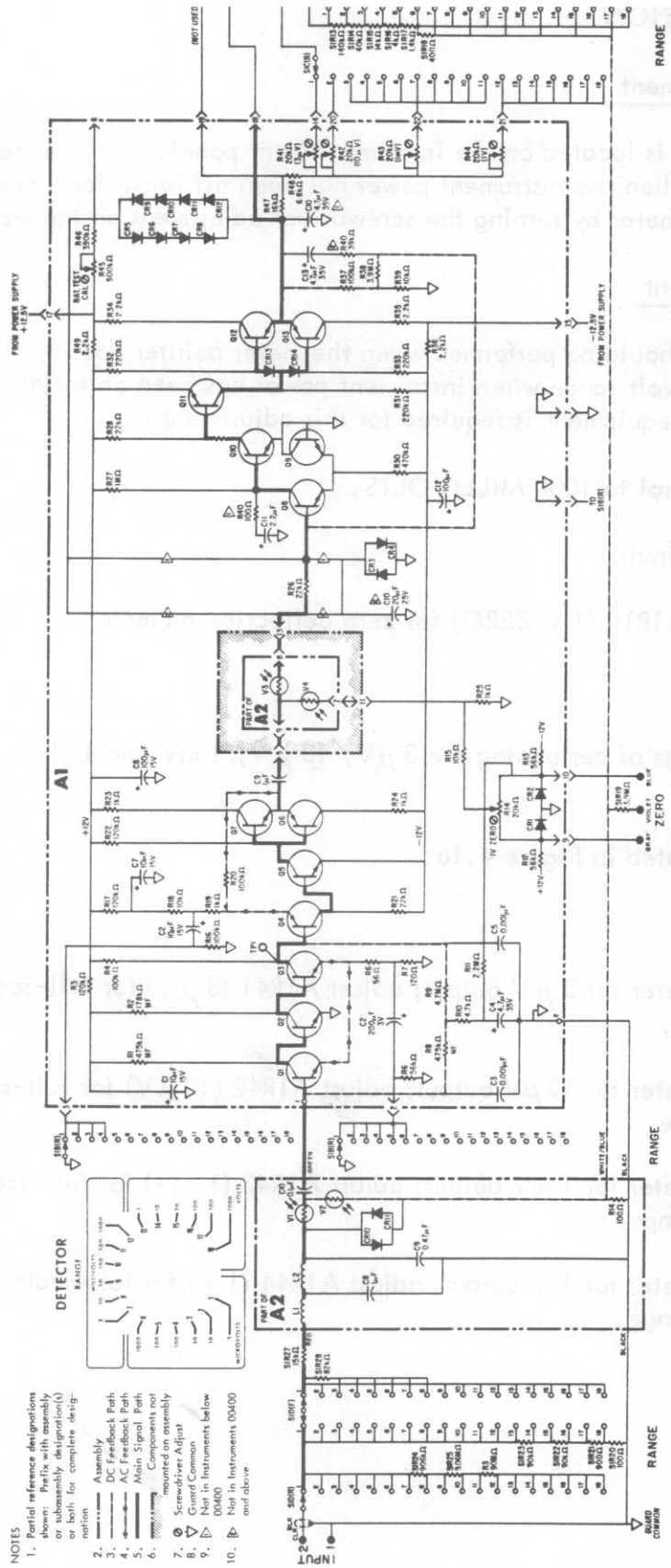
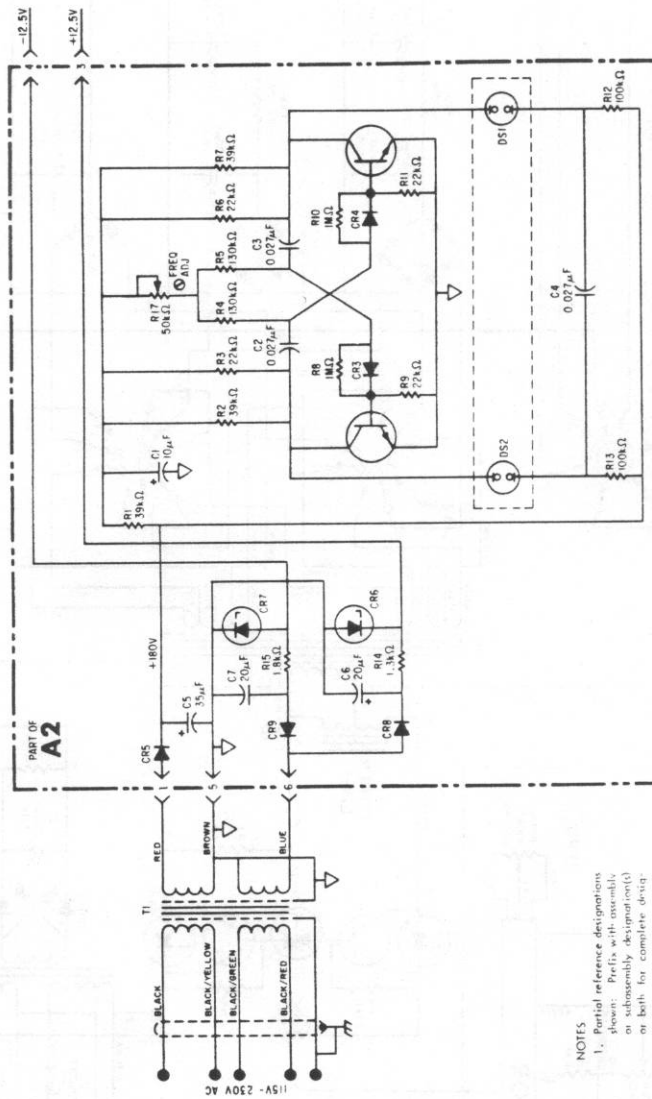

Figure 4.2 Detector, Schematic Diagram

- NOTES**
1. Partial reference designations are shown with a subassembly designation (A) or both for complete designation.
 2. Assembly notations.
 3. DC Feedback Path.
 4. AC Feedback Path.
 5. Main Signal Path.
 6. Components not mounted on assembly.
 7. Screwdriver Adjust.
 8. Common.
 9. Not in Instruments below 00400.
 10. Not in Instruments 00400 and above.



NOTES
 1. Partial reference designations shown: Prefix with assembly or subassembly designation(s) or both, for complete designation.

Figure 4.3 Detector Power Supply and Lamp Driver, Schematic Diagram

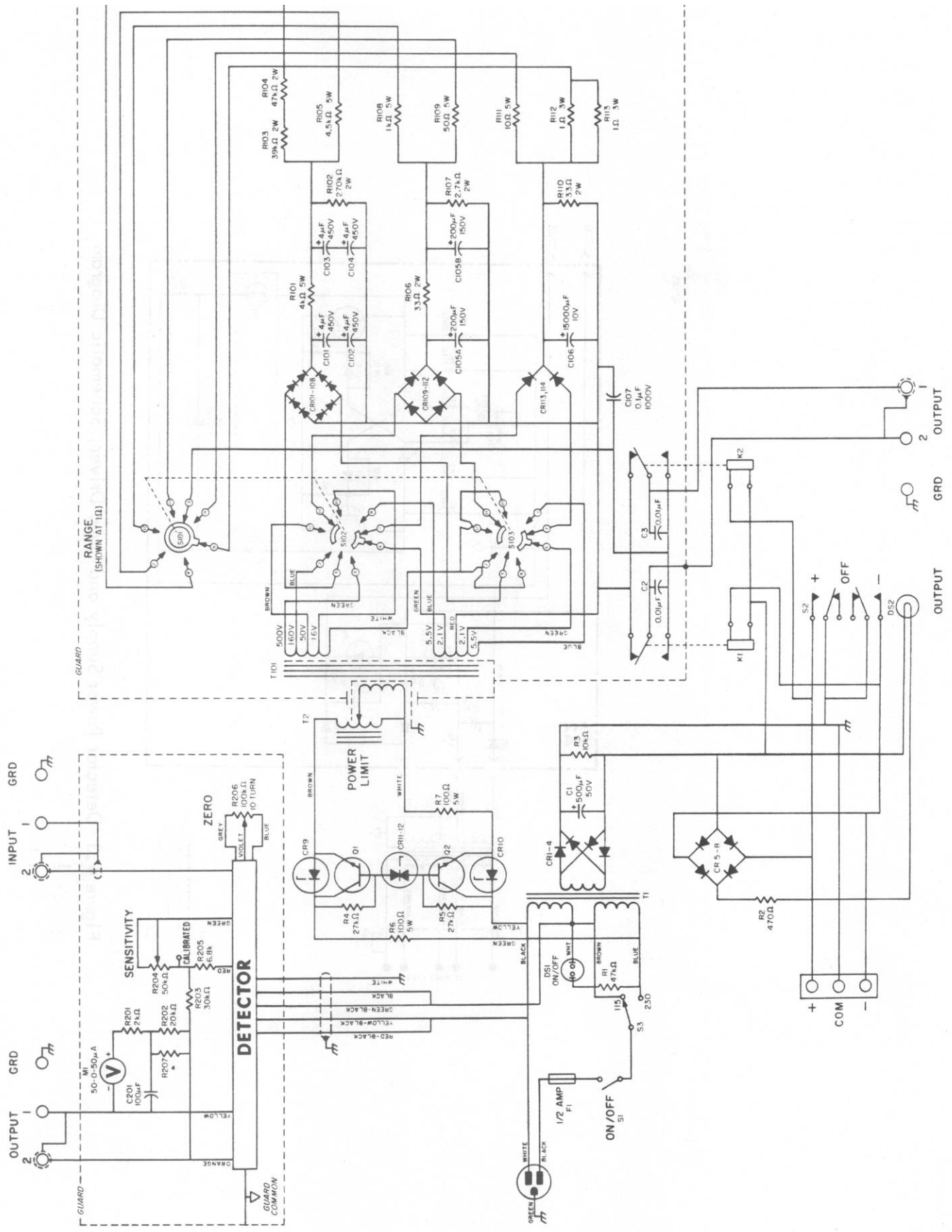

Figure 4.4 Schematic Diagram

4.5 PARTS LIST

The following parts list is in alpha-numerical order of the circuit reference designator. Miscellaneous parts are included at the end of the list. Manufacturer of the part is given in a code number according to the Federal Supply Code for Manufacturers (see list of manufacturers below).

Parts manufactured by Electro Scientific Industries must be ordered from the factory. When ordering, include the following information:

Model and serial number of the instrument
 Electro Scientific Industries part number
 Circuit reference designator
 Description of part

CODE LIST OF MANUFACTURERS

00656 AEROVOX CORP., New Bedford, Massachusetts
 01121 ALLEN BRADLEY COMPANY, Milwaukee, Wisconsin
 01295 TEXAS INSTRUMENTS, INC., Dallas, Texas
 02735 RADIO CORP. OF AMERICA, Somerville, New Jersey
 03797 ELDEMA CORP., El Monte, California
 04713 MOTOROLA, INC., Phoenix, Arizona
 11837 ELECTRO SCIENTIFIC INDUSTRIES, INC., Portland, Oregon
 12697 CLAROSTAT MFG. CO., Dover, New Hampshire
 14655 CORNELL DUBILIER ELEC. CORP., South Plainfield, New Jersey
 28480 HEWLETT-PACKARD COMPANY, Palo Alto, California
 37942 P. R. MALLORY & CO., INC., Indianapolis, Indiana
 56289 SPRAGUE ELECTRIC COMPANY, North Adams, Massachusetts
 58474 SUPERIOR ELECTRIC COMPANY, Bristol, Connecticut
 71482 C. P. CLARE, Chicago, Illinois
 73138 BECKMAN INSTRUMENTS, INC., Helipot Division, Fullerton, California
 73631 CURTIS DEV. & MFG. COMPANY, Milwaukee, Wisconsin
 75915 LITTLEFUSE, INC., Des Plaines, Illinois
 76487 JAMES MILLEN MFG. CO., INC., Malden, Massachusetts
 76854 OAK MANUFACTURING CO., Crystal Lake, Illinois
 82389 SWITCHCRAFT, INC., Chicago, Illinois

CKT REF	DESCRIPTION	MFR CODE	MFR PART NUMBER	ESI PART NUMBER	QTY USED
A1	Detector Amplifier Circuit Assembly	28480	00419-66501B	18409	1
A2	Detector Power Supply Circuit Assembly	28480	00419-66503	18408	1
C1	Capacitor, 500 μ F, 50V (-10% + 75%)	56289	39D507G050GL4	1942	1
C2, 3	Capacitor, 0.01 μ F, 1000V (\pm 10%)	56289	41C121A1	1918	2
C101-104	Capacitor, 4 μ F, 450V (-10% + 100%)	00656	1710	2183	4
C105 A,B	Capacitor, 200 μ F, 150V (-10% + 75%)	14655	BR200-150	2138	2
C106	Capacitor, 18,000 μ F, (-10% + 75%)	37942	CG193U10D1	8035	1
C107	Capacitor, 0.1 μ F, 1000V (\pm 10%)	00656	BE10P1	50013	1
C201	Capacitor, 100 μ F, 12V (-10% + 50%)	56289	TE1135	6157	1
CR1-8, 101-114*	Diode, Type IN4005 or Equal	04713	IN4005	1779	22
CR9, 10	Diode, Zener, 200 volts, 1 watt, 10%				2
CR11,12	Diode, Zener, 160 volts	04713	IN3049B	18453	2

* These apply to Figure 4.4 schematic only.

<u>CKT REF</u>	<u>DESCRIPTION</u>	<u>MFR CODE</u>	<u>MFR PART NUMBER</u>	<u>ESI PART NUMBER</u>	<u>QTY USED</u>
DS2	Pilot Light, Generator OUTPUT	03797	CF03-RTS-176	18412	1
F1	Fuse, 1/2A	75915	3AG 1/2	1802	1
K1, 2	Relay, Guarded	71482	A-131142	18439	2
M1	Meter	11837	18410	18410	1
Q1, 2	Transistor, Type 40318 or Equal	02735	40318	18452	2
R206	Potentiometer, 100k Ω , 10 Turn, ZERO	12697	62JA	18414	1
R204	Potentiometer Switch Assembly, 50k Ω , SENSITIVITY	01121	JS-93392	18413	1
R1	Resistor, 47k Ω , 1/2 watt, 10%	01121	EB4731	1958	1
R2	Resistor, 470 Ω , 1/2 watt, 10%	01121	GB4711	2056	1
R3	Resistor, 10k Ω , 1/2 watt, 10%	01121	EB1031	1961	1
R4, 5	Resistor, 27k Ω , 1/2 watts, 10%	01121	EB2731	1062	2
R6, 7	Resistor, 100 Ω , 5 watts, 10%	12697	BC5E	1990	2
R101	Resistor, 4k Ω , 5 watts, 5%	12697	VC5E	2484	1
R102	Resistor, 270k Ω , 2 watts, 10%	01121	HB2741	1645	1
R103	Resistor, 39k Ω , 2 watts, 10%	01121	HB3931	2469	1
R104	Resistor, 47k Ω , 2 watts, 10%	01121	HB4731	2474	1
R105	Resistor, 4.5k Ω , 5 watts, 5%	12697	VC5E	2070	1
R106, 110	Resistor, 33 Ω , 2 watts, 10%	01121	HP3301	2045	2
R107	Resistor, 2.7k Ω , 2 watts, 10%	01121	HB2721	2065	1
R108	Resistor, 1k Ω , 5 watts, 5%	12697	VPR5F-1K	2061	1
R109	Resistor, 50 Ω , 5 watts, 5%	12697	VC5E-50 Ω	2047	1
R111	Resistor, 10 Ω , 5 watts, 5%	12697	VPR5F	2040	1
R112, 113	Resistor, 1 Ω , 3 watts, 5%	12697	VC3D	2036	2
R201	Resistor, 2k Ω , 1/2 watt, 1%	00656	CPSX-1/2	2062	1
R202	Resistor, 20k Ω , 1/2 watt, 1%	00656	CPSX-1/2	1987	1
R203	Resistor, 30k Ω , 1/2 watt, 1%	00656	CPSX-1/2	2458	1
R205	Resistor, 6.8k Ω , 1/2 watt, 10%	01121	EB6821	2075	1
S1/DS1	Switch and Pilot Light Assembly ON/OFF	76854	616-26-A16	18418	1
S2	Switch, Lever, Generator OUTPUT	11837	3071	3071	1
S3	Switch, DPDT, (115-230)	82389	H6206LF	18424	1
S101-103	Switch, Generator RANGE	11837	8050	8050	1
T1	Transformer, Relay Supply	11837	18445	18445	1
T2	Variable Autotransformer, POWER LIMIT	58474	10B	8068	1
T101	Transformer, Generator	11837	8091	8091	1
	Barrier Strip, 3 Terminal	73631	GFTC-3	18415	1
	Binding Post, Guarded	11837	1480	1480	3
	Binding Post, 1 Inch Long	11837	1396	1396	6
	Cap, Binding Post, Black	11837	1170	1170	6
	Cap, Binding Post, Gold Plated	11837	1172	1172	6
	Detector Assembly	28480	00419	18411	1
	Dust Cover	11837	18446	18446	1
	Fuseholder	75915	342014	18416	1
	Generator Power Supply Assembly	11837	18420	18420	1
	Knob, Large Bar, Filled	11837	1266	1266	2
	Knob, Large Round, Filled	11837	1271	1271	1
	Knob, Small Round, Filled	11837	1268	1268	1

<u>CKT REF</u>	<u>DESCRIPTION</u>	<u>MFR CODE</u>	<u>MFR PART NUMBER</u>	<u>ESI PART NUMBER</u>	<u>QTY USED</u>
	Panel, Front	11837	18419	18419	1
	Power Cord	11837	2520	2520	1
	Printed Circuit Board Assembly, Capacitor	11837	18870	18870	1
	Printed Circuit Board Assembly, Diode	11837	18435	18435	1
	Printed Circuit Board Assembly, Meter	11837	18449	18449	1
	Printed Circuit Board Assembly, Relay Power	11837	18437	18437	1
	Shaft Coupler, Insulating	76487	39002	8052	2
	Slides	11837	82579	82579	2



13900 N. W. SCIENCE PARK DRIVE
PORTLAND, OREGON 97229
(area code 503) 646-4141
cable address: ESIACTION

WARRANTY OF TRACEABILITY

THE REFERENCE STANDARDS OF MEASUREMENT OF ELECTRO SCIENTIFIC INDUSTRIES INC. ARE COMPARED WITH THE U.S. NATIONAL STANDARDS THROUGH FREQUENT TESTS BY THE U.S. NATIONAL BUREAU OF STANDARDS.

THE ESI WORKING STANDARDS AND TESTING APPARATUS USED ARE CALIBRATED AGAINST THE REFERENCE STANDARDS IN A RIGOROUSLY MAINTAINED PROGRAM OF MEASUREMENT CONTROL.

THE MANUFACTURE AND FINAL CALIBRATION OF THIS INSTRUMENT WERE CONTROLLED BY THE USE OF THE ESI REFERENCE AND WORKING STANDARDS AND TESTING APPARATUS IN ACCORDANCE WITH ESTABLISHED PROCEDURES AND WITH DOCUMENTED RESULTS. (REFERENCE MIL-C-45662)



Electro Scientific Industries, Inc.

13900 N. W. SCIENCE PARK DRIVE
PORTLAND, OREGON 97229
(area code 503) 646-4141 •
cable address: ESIACTION

WARRANTY OF QUALITY

ELECTRO SCIENTIFIC INDUSTRIES, INC. WARRANTS ITS PRODUCTS TO BE FREE FROM DEFECTS IN MATERIAL AND WORKMANSHIP. FOR A PERIOD OF TWO YEARS FROM THE DATE OF SHIPMENT TO THE ORIGINAL PURCHASER, WE WILL SERVICE OR, AT OUR OPTION, REPLACE ANY DEVICE WHICH FAILS IN NORMAL USE TO MEET ITS PUBLISHED SPECIFICATIONS.

BATTERIES AND TUBES WHICH HAVE GIVEN NORMAL

SERVICE ARE EXCEPTED.



WARRANTY OF QUALITY

ELECTRO SCIENTIFIC INDUSTRIES, INC. WARRANTS ITS PRODUCTS TO BE

FREE FROM DEFECTS IN MATERIAL AND WORKMANSHIP FOR A PERIOD

OF TWO YEARS FROM THE DATE OF SHIPMENT TO THE ORIGINAL

PURCHASER. WE WILL SERVICE OR, AT OUR OPTION, REPLACE ANY

DEVICE WHICH FAILS IN NORMAL USE TO MEET ITS PUBLISHED

SPECIFICATIONS

BATTERIES AND TUBES WHICH HAVE GIVEN NORMAL

SERVICE ARE EXCEPTED

Would you like more information?

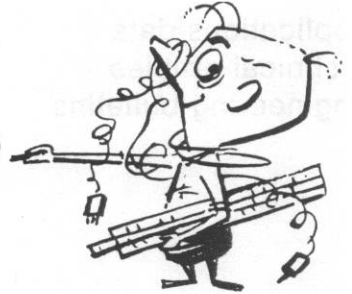

There is a complete bibliography of ESI technical publications on the opposite side of this page. Underline the titles or order numbers of any publications you would like us to send. If there is any information that you would like to have, or if there is any comment you would like to make concerning the instrument or instruction manual, please fill out this page.

Instrument Description: Model No. _____ Serial No. _____
(Please Print)

Name _____ Title _____

Department _____ Mail Stop _____

Company _____

Address _____

City _____ State _____ Zip Code _____

Any comments or corrections? _____

Mail this page to:



Electro Scientific Industries, Inc.

13900 N.W. Science Park Drive

Portland, Oregon 97229

Attention:

Engineering Literature Department

applications data
technical articles
engineering bulletins

Order No.

- EB7** Measuring Three-Terminal Capacitors, *March 1962*
- EB10** Effects of Output Loading on Resistive Voltage Dividers, *October 1966*
- EB11** To Use an External Q Rheostat for Inductance Measurements with the ESI Model 250 Bridge, *May 1962*
- EB15** Low Input Resistance Voltage Dividers, *March 1960*
- EB20** Calibration of a Decade Transformer Having One PPM Linearity, *N. E. Morrison, April 1960*
- EB23** A New Approach to Bridge Sensitivity, *Jack Riley, November 1962*
- EB24** Calibration of a Kelvin Varley Voltage Divider, *Merle L. Morgan and Jack Riley, August 1960*
- EB26** International System of Units, *August 1964*
- EB29** DC and Low Frequency AC Ratio Measurements, *Dr. Merle L. Morgan, September 1962*
- EB31** Transformer Bridge Theory and Practice, *Jack C. Riley, January 1964*
- EB35** An Improved Technique for Establishing Resistance Ratios, *R. M. Pailthorp and J. C. Riley, November 1962*
- EB41** Derivation of Electrical Units from Fundamental Standards, *R. D. Kuykendall and R. M. Pailthorp, July 1964*
- EB43** Metrology Seminar WESCON 1964, *September 1964*
- EB44** DC Measurements Using Ratio Techniques, *Jack C. Riley, September 1965*
- TA2** A Ratio Transformer Bridge for Standardization of Inductors and Capacitors, *D. L. Hillhouse and H. W. Kline, August 1960*
- TA6** The Accuracy of Series and Parallel Connections of Four-Terminal Resistors, *Jack C. Riley, April 1965*
- TA7** Design of a Contemporary Direct Reading Double Ratio Set and Auxiliary Lead Compensator, *Marion Roberts, April 1965*
- TA8** AC Measurements Using Ratio Techniques, *Jack C. Riley, May 1965*
- TA9** Strength for the Weak Spot in DC Potentiometry, *George D. Vincent and M. L. Roberts, October 1965*
- TA10** Resonant Capacitance-Inductance Transfer Using the Ratio Transformer, *D. L. Hillhouse, July 1966*
- TA11** An International Comparison of Inductive Voltage Divider Calibrations at 400 and 1000 Hz, *W. C. Sze, A. F. Dunn, and T. L. Zapf, January 1967*
- TA12** On Resistances with Current and Potential Terminals, *G. F. C. Searle, January 1967*
- TA13** A 1-100 Ω Build-Up Resistor for the Calibration of Standard Resistors, *B. V. Hamon, January 1967*
- TA14** The Advantages of a Ten Kiloohm Transportable Resistance Standard, *Robert M. Pailthorp, September 1967*
- TA15** A Programmable System for Instrument Calibration, *Richard A. Schomburg, October 1967*
- TA16** Which Bridge for Precise Resistance Measurements? *Edward J. Swenson and George D. Vincent, December 1967*





Electro Scientific Industries, Inc.

13900 N. W. SCIENCE PARK DRIVE
PORTLAND, OREGON 97229
(area code 503) 646-4141 • telex: 036-600

WARRANTY OF TRACEABILITY

Electro Scientific Industries, Inc. maintains reference standards of measurement which are compared with the U. S. National Standards through frequent tests by the U. S. National Bureau of Standards.

ESI working standards and testing apparatus used are calibrated against the ESI reference standards in a rigorously maintained program of measurement control.

The manufacture and final calibration of all ESI instruments are controlled by use of the ESI reference and working standards and testing apparatus in accordance with established procedures and documented results. (Reference MIL-C-45662)

Final calibration of this instrument was performed with reference to the mean values of the ESI reference standards or to ratio devices that were verified at the time and place of use.



Electro Scientific Industries, Inc.

WARRANTY OF TRACEABILITY

Electro Scientific Industries, Inc. maintains reference standards of measurement which are compared with the U.S. National Standards through frequent test by the U.S. National Bureau of Standards.

ESL working standards and testing apparatus used are calibrated against the U.S. reference standards in a rigorously maintained program of measurement control.

The manufacture and final calibration of all ESL instruments are controlled by use of the ESL reference and working standards and testing apparatus in accordance with established procedures and documented tests. Reference MIL-C-42662.

Final calibration of this instrument was performed with reference to the best values of the ESL reference standards or to this device that were verified at the time and place of use.



Electro Scientific Industries, Inc.

13900 N. W. SCIENCE PARK DRIVE
PORTLAND, OREGON 97229
(area code 503) 646-4141 • telex: 036-60

WARRANTY OF QUALITY

Electro Scientific Industries, Inc. warrants its products to be free from defects in material and workmanship for the following periods:

1. Two years for components and instruments using passive circuitry.
One year for repairs of out-of-warranty items.
2. One year for components and instruments using active circuitry (see ESI Metrology Catalog). Six months for repairs of out-of-warranty items.

During the in-warranty periods, we will service or, at our option, replace any device that fails in normal use to meet its published specifications. Batteries, tubes and relays that have given normal service are excepted.

Electro Scientific Industries, Inc.



WARRANTY OF QUALITY

Electro Scientific Industries, Inc. warrants its products to be free from defects in material and workmanship for the following periods:

1. Two years for components and instruments using active electronic tubes.
2. One year for components and instruments using active electronic tubes.
3. One year for components and instruments using active electronic tubes.

During the in-warranty periods, we will service or, at our option, replace any device that fails in normal use to meet its published specifications. Batteries, tubes and relays that have given normal service are excluded.

Would you like more information?

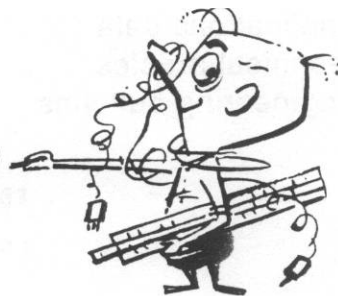

There is a complete bibliography of ESI technical publications on the opposite side of this page. Underline the titles or order numbers of any publications you would like us to send. If there is any information that you would like to have, or if there is any comment you would like to make concerning the instrument or instruction manual, please fill out this page.

Instrument Description: Model No. _____ Serial No. _____
(Please Print)

Name _____ Title _____

Department _____ Mail Stop _____

Company _____

Address _____

City _____ State _____ Zip Code _____

Any comments or corrections? _____

Mail this page to:



Electro Scientific Industries, Inc.

13900 N.W. Science Park Drive

Portland, Oregon 97229

Attention: Literature Department

- applications data
- technical articles
- engineering bulletins

- EB-10** Effects of Output Loading on Resistive Voltage Dividers, October 1969
- EB-11** To Use an External Q Rheostat for Inductance Measurements with the ESI Model 250 Bridge, May 1962
- EB-15** Low Input Resistance Voltage Dividers, February 1970
- EB-17** Accuracy Versus Frequency of Models 290B and 250DE Universal Impedance Bridges, May 1969
- EB-26** International System of Units, August 1969
- EB-29** DC and Low Frequency AC Ratio Measurements, Dr. Merle L. Morgan, September 1962
- EB-30** Traceability of Resistance Measurements, Jack C. Riley, January 1964
- EB-34** Resistance Transfer Technique, Lawrence H. White, April 1968
- EB-35** An Improved Technique for Establishing Resistance Ratios, R. M. Pailthorp and J. C. Riley, November 1962
- EB-41** Derivation of Electrical Units from Fundamental Standards, R. D. Kuykendall and R. M. Pailthorp, July 1964
- EB-44** DC Measurements Using Ratio Techniques, Jack C. Riley, September 1965
- TA-6** The Accuracy of Series and Parallel Connections of Four-Terminal Resistors, Jack C. Riley, April 1965
- TA-8** AC Measurements Using Ratio Techniques, Jack C. Riley, May 1965
- TA-9** Strength for the Weak Spot in DC Potentiometry, George D. Vincent and M. L. Roberts, October 1965
- TA-14** The Advantages of a Ten Kilohm Transportable Resistance Standard, Robert M. Pailthorp, September 1967
- TA-16** Which Bridge for Precise Resistance Measurements?, Edward J. Swenson and George D. Vincent, December 1967
- TA-17** Experimental Verification of the Five-Terminal, Ten-Kilohm Resistor as a Device for Dissemination of the Ohm, George D. Vincent and Robert M. Pailthorp, December 1968
- TA-22** Laser Resistance Trimming from the Measurement Point of View, Arthur G. Albin and Edward J. Swenson, June 1971
- TA-23** Precision Measurement of Resistor Networks, Robert M. Pailthorp and Jack C. Riley, June 1971
- TA-24** Predictive Adjustment of Tantalum Film Resistors by Anodization, Donald R. Cutler and Edward J. Swenson, July 1971

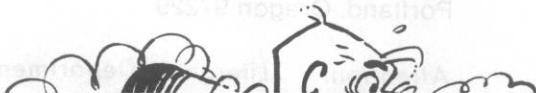

Parts List
ESI MODEL 240

Ckt Ref	Description	Mfr.	ESI Part No.	Qty Used	Recm SP
	<u>MISCELLANEOUS</u>				
	Cover, Dust	11837	1583	1	
	KELVIN KLIP Ass'y	11837	8309	2	2
	Connector	11837	8307	2	1
	Insulator, Switch Stacking Bolt	11837	2326	6	2
	Insulator, Binding Post, Rear	11837	8823	12	
	Window, Lead Adj	11837	8368	1	
	Post, Binding	11837	1393	16	
	Bushing, Deviation Dial	11837	2799	1	
	Cap, Binding Post, Metal	11837	1172	4	2
	Cap, Binding Post, Ins.	11837	1170	12	5
	Knob	11837	1270	2	
	Dial, Lead Adjust	11837	8361	1	
	Dial, Std. Multiplier	11837	8375	1	
	Dial, Deviation Multiplier	11837	8372	1	
	Dial, Deviation	11837	8370	1	
	Index, Lead Adj	11837	8360	1	
	Mask, Deviation Multiplier Dial	11837	7051	1	

Part No.	Part Name	QTY	Unit	Description
11837	1582	1		MISCELLANEOUS
11837	8309	1		Control, Dial
11837	8307	1		RELAY KILB A...
11837	4126	1		Connector
11837	8812	1		Isolator, Switch
11837	8812	1		Isolator, Binding Post
11837	8803	1		Window, Lead Ad.
11837	1393	1		Post, Binding
11837	3799	1		Binding, Deviation Dial
11837	1172	1		Cap, Binding Post
11837	1170	1		Cap, Binding Post, Ins.
11837	1270	1		Knob
11837	8507	1		Dial, Lead Ad.
11837	837	1		Dial, Std. Multiplier
11837	872	1		Dial, Deviation Multiplier
11837	870	1		Dial, Deviation
11837	8300	1		Index, Lead Ad.
11837	7081	1		Mask, Deviation Multiplier Dial